

FORTiS-N™ enclosed encoder system Functional Safety installation guide and safety manual



This page is left intentionally blank.

Contents

1	Legal notices	6
1.1	Patents	6
1.2	Terms and Conditions and Warranty	6
1.3	Declaration of Conformity	6
1.4	Product compliance	6
1.5	Federal Code Of Regulation (CFR) FCC Part 15 – RADIO FREQUENCY DEVICES	7
1.6	Intended use	7
1.7	Warnings	7
1.8	Packaging	8
1.9	REACH regulation	8
1.10	Disposal of waste electrical and electronic equipment	8
1.11	Further information	8
2	Definitions	9
3	Information for use	9
4	Functional Safety data declaration	10
5	Safety function	11
5.1	Fault exclusions	11
5.2	Failure modes effects and diagnostics analysis	11
5.3	Installation	11
5.4	Commissioning test	11
5.5	Evaluation unit monitoring	12
5.6	Maintenance	12
5.7	Repair	12
5.8	Proof testing	12

6	Certification	13
7	Summary of EU declaration of conformity	13
8	Summary of UK declaration of conformity	14
9	Overview of the FORTiS-N FS encoder system	15
10	Parts list	16
10.1	Included in the box	16
10.2	Not included / required tools	17
10.3	Optional extras	18
10.4	Cable options	18
11	Storage and handling	19
12	Installation drawings	20
12.1	Mounting surface preparation	20
12.2	Datum location edge or dowel pins – standard end caps	20
12.3	Mounting orientations – standard end caps	21
12.4	Mounting orientations – short end caps	21
12.5	FORTiS system installation drawing – standard end caps	22
12.6	FORTiS system installation drawing – short end caps	23
13	Product specification	24
14	Installation procedure – extrusion	25
14.1	Protection for sealed linear encoders	25
14.2	Thermal datum	25
14.3	Extrusion installation without mounting spar	26
14.4	Installation with mounting spar	27
14.5	Mounting spar installation drawing	28
14.6	Spar mounting options	29

15 Installation procedure – readhead	30
15.1 Start of measuring length – standard	30
15.2 Start of measuring length – short end caps	30
15.3 Alignment bracket method	31
15.4 Set-up shim method	33
15.5 Installation using the mounting aid method	35
15.6 FORTiS cable connection	37
15.7 Validating an installation	38
15.8 Air supply	39
16 Cables and serial interfaces	40
16.1 General specifications	40
16.2 Permissible cable lengths	40
16.3 BiSS Safety serial interface	42
16.4 Siemens DRIVE-CLiQ serial interface	44

1 Legal notices

1.1 Patents

Features of Renishaw's encoder systems and similar products are the subjects of the following patents and patent applications:

CN1260551	US7499827	JP4008356	GB2395005	US20100163536
US20150225858	CN102197282	EP2350570	JP5480284	US8505210
KR1630471	CN102388295	EP2417423	KR1701535	US2012007980
CN102460077	EP2438402	US20120072169	KR1851015	JP6074392
JP5755223	EP01103791	US6465773		

1.2 Terms and Conditions and Warranty

Unless you and Renishaw have agreed and signed a separate written agreement, the equipment and/or software are sold subject to the Renishaw Standard Terms and Conditions supplied with such equipment and/or software, or available on request from your local Renishaw office.

Renishaw warrants its equipment and software for a limited period (as set out in the Standard Terms and Conditions), provided that they are installed and used exactly as defined in associated Renishaw documentation. You should consult these Standard Terms and Conditions to find out the full details of your warranty.

Equipment and/or software purchased by you from a third-party supplier is subject to separate terms and conditions supplied with such equipment and/or software. You should contact your third-party supplier for details.

1.3 Declaration of Conformity

Renishaw plc hereby declares that the FORTiS-N™ encoder system is in compliance with the essential requirements and other relevant provisions of:

- the applicable EU directives
- the relevant statutory instruments under UK law.



The full text of the Declaration of Conformity is available at: www.renishaw.com/productcompliance

1.4 Product compliance

This document is an installation guide and safety manual which details the actions required for the safe integration of the FORTiS-N FS encoder system with BiSS Safety or Siemens DRIVE-CLiQ serial interfaces, as designated by the letter S in this location in the part number, e.g. FN100A012HC28DS050X, into a functionally safe system.



The FORTiS-N FS encoder system is suitable for use in a Category 3 performance level d (PLd) application in compliance with ISO 13849-1 and in a safety integrity level 2 (SIL2) application in compliance with IEC 61508-1 and IEC 61800-5-2 when installed and operated in accordance with the instructions defined. Failure to follow the correct use instructions and failure to heed the limitations may result in SIL2 and/or PLd not being achieved and will invalidate the Functional Safety certification.

A copy of the FORTiS-N FS encoder system certificate is available from our website: www.renishaw.com/productcompliance

1.5 Federal Code Of Regulation (CFR) FCC Part 15 – RADIO FREQUENCY DEVICES

FCC Compliance Statement

47 CFR Section 15.19

This device complies with part 15 of the FCC Rules. Operation is subject to the following two conditions:

1. This device may not cause harmful interference, and
2. This device must accept any interference received, including interference that may cause undesired operation.

47 CFR Section 15.21

The user is cautioned that any changes or modifications not expressly approved by Renishaw plc or authorised representative could void the user's authority to operate the equipment.

47 CFR Section 15.105

This equipment has been tested and found to comply with the limits for a Class A digital device, pursuant to part 15 of the FCC Rules. These limits are designed to provide reasonable protection against harmful interference when the equipment is operated in a commercial environment. This equipment generates, uses, and can radiate radio frequency energy and, if not installed and used in accordance with the instruction manual, may cause harmful interference to radio communications. Operation of this equipment in a residential area is likely to cause harmful interference in which case the user will be required to correct the interference at their own expense.

47 CFR Section 15.27

This unit was tested with shielded cables on the peripheral devices. Shielded cables must be used with the unit to ensure compliance.

Supplier's Declaration of Conformity

47 CFR § 2.1077

Unique Identifier: FORTiS-N

Responsible Party – U.S. Contact Information

Renishaw Inc.

1001 Wesemann Drive

West Dundee

Illinois

IL 60118

United States

Telephone number: +1 847 286 9953

Email: usa@renishaw.com

ICES-003 – Information Technology Equipment (including Digital Apparatus)

This ISM device complies with Canadian ICES-003(A).

Cet appareil ISM est conforme à la norme ICES-003(A).

1.6 Intended use

The FORTiS encoder system is designed for metrology in industrial environments, such as machine tools. It must be installed, operated, and maintained as specified in Renishaw documentation and in accordance to the Standard Terms and Conditions of the Warranty and all other relevant legal requirements.

1.7 Warnings

In all applications involving the use of machine tools, eye protection is recommended.

1.8 Packaging

The packaging of our products contains the following materials and can be recycled.

Packaging components			
Packaging component	Material	ISO 11469	Recycling guidance
Wooden box	Plywood and softwood	Not applicable	Recyclable
Outer box	Cardboard	Not applicable	Recyclable
	Polypropylene	PP	Recyclable
Inserts	Low density polyethylene foam	LDPE	Recyclable
	Cardboard	Not applicable	Recyclable
Bags	High density polyethylene bag	HDPE	Recyclable
	Metalised polyethylene	PE	Recyclable

1.9 REACH regulation

Information required by Article 33(1) of Regulation (EC) No. 1907/2006 ("REACH") relating to products containing substances of very high concern (SVHCs) is available at:

www.renishaw.com/REACH

1.10 Disposal of waste electrical and electronic equipment



The use of this symbol on Renishaw products and/or accompanying documentation indicates that the product should not be mixed with general household waste upon disposal. It is the responsibility of the end user to dispose of this product at a designated collection point for waste electrical and electronic equipment (WEEE) to enable reuse or recycling. Correct disposal of this product will help to save valuable resources and prevent potential negative effects on the environment. For more information, contact your local waste disposal service or Renishaw distributor.

1.11 Further information

Further information relating to the FORTiS encoder range can be found in the FORTiS data sheets available from your local Renishaw representative or from our website:

www.renishaw.com/fortisdownloads

For further details regarding FORTiS enclosed linear encoder variants refer to the following table.

Encoder system description	Part numbers	
	Data sheet	Installation guide
FORTiS-S	L-9517-9934	M-9768-9857
FORTiS-S enclosed encoder system with multiple readheads	Refer to installation guide	M-6725-9176
FORTiS-S functional safety (FS) system	L-9517-9958	M-6725-9016
FORTiS-S functional safety (FS) system with multiple readheads	Refer to installation guide	M-6725-9188
FORTiS-N	L-9517-9946	M-9768-9887
FORTiS-N enclosed encoder system with multiple readheads	Refer to installation guide	M-6725-9200
FORTiS-N functional safety (FS) system	L-9517-9970	M-6725-9026
FORTiS-N functional safety (FS) system with multiple readheads	Refer to installation guide	M-6725-9212

2 Definitions

WARNING A hazard with a medium risk of injury if not avoided

ESD handling



The ESD Susceptibility Symbol consists of a triangle, a reaching hand, and a slash through the reaching hand. The triangle means “**Caution**” and the slash through the reaching hand means “**Don’t touch**”.

Mechanical safe position

The maximum distance the scale might move from its installed position, for example if the fixings work loose.

Evaluation unit

External item of equipment in which the output signal of the encoder is evaluated: for example, machine controller or safety relay.

System manufacturer

Personnel with responsibility for selecting the encoder and verifying its capability is appropriate for the safety-related application.

System installer

Personnel with responsibility for fitting the encoder in the specific application.

3 Information for use

WARNING Not to be used in environments where there is an explosive atmosphere

WARNING Not to be used by medical devices

The FORTiS-N FS encoder system is designed to be used as part of a safety-related control system as specified by the system manufacturer. It is the responsibility of the system manufacturer to set the evaluation unit to implement the appropriate actions when the FORTiS-N FS encoder system reports an error. The decision to use this system for the intended purpose is the responsibility of the system manufacturer. The FORTiS-N FS encoder system is certified to the SIL and PL levels as shown in the “Functional Safety data declaration” table; however, the system manufacturer must conduct their own assessment of the full system to determine its safety capability.

Correct use includes:

- Operating the FORTiS-N FS encoder system within the limits defined in this document.
- Installing the system as described in this document.
- Maintaining the system as described in this document.

System components covered by this installation guide:

The FORTiS-N FS encoder system comprises the following parts:

- FORTiS-N FS encoder unit
- Accessories
- Cable
- Extension cable (when required)
- DRIVE-CLiQ interface (when required)

NOTE: If the original termination supplied with the FORTiS-N FS encoder system is altered or a non-Renishaw cable that is not approved is used, then it is the responsibility of the system manufacturer to make sure the system is compliant with IEC 61800-5-2:2016 *Electromagnetic immunity requirement for safety related systems – Annex E, second environment*.

4 Functional Safety data declaration

Product identification FORTiS-N FS with BiSS Safety and
Siemens DRIVE-CLiQ serial interfaces

IEC 61508 safety data

Safety integrity level	2	
Random hardware failures (per hour) – BiSS Safety serial interface	λ_s	= 2.60E-07
	λ_D	= 4.08E-07
	λ_{DD}	= 3.67E-07
	λ_{DU}	= 4.08E-08
Random hardware failures (per hour) – Siemens DRIVE-CLiQ serial interface	λ_s	= 3.46E-07
	λ_D	= 6.02E-07
	λ_{DD}	= 5.42E-07
	λ_{DU}	= 6.02E-08
PFD _{avg}	Not applicable due to continuous demand mode	
PFH (per hour) – BiSS Safety serial interface	λ_{DU}	= 4.08E-08
PFH (per hour) – Siemens DRIVE-CLiQ serial interface	λ_{DU}	= 6.02E-08
Architectural constraints	Type	B
	HFT	0
	SFF	94%
Hardware safety integrity compliance	Route 1H	
Systematic safety integrity compliance	Route 1S	
Systematic capability	SC 2	
Demand mode	Continuous	
Proof test interval	Not required for continuous demand mode	

ISO 13849 safety data

MTTF _D – BiSS Safety serial interface	292 years
MTTF _D – Siemens DRIVE-CLiQ serial interface	189 years
Diagnostic coverage	Medium (90%)
Category	3
Performance level	d
Lifetime/replacement limits	20 years

The FORTiS-N FS encoder system provides safe position data that supports the following safety sub-functions defined by IEC 61800-5-2:

- Safe stop 1 (SS1) and Safe stop 2 (SS2) ¹
- Safe operating stop (SOS) ¹
- Safe limited acceleration (SLA) $\leq 200 \text{ m/s}^2$
- Safe acceleration range (SAR) $\leq 200 \text{ m/s}^2$
- Safe limited speed (SLS) $\leq 4 \text{ m/s}$
- Safe speed range (SSR) $\leq 4 \text{ m/s}$
- Safely limited position (SLP) ¹
- Safely limited increment (SLI) ¹
- Safe direction (SDI)
- Safe speed monitor (SSM) $\leq 4 \text{ m/s}$

¹ See the safety function restrictions for the safe position figure for each FORTiS-N FS encoder system variant.

5 Safety function

The FORTiS-N FS encoder system shall provide a safe position when requested by the evaluation unit.

The following restrictions apply to this claim:

- The system installer must perform a verified commissioning test during installation.
- The system repairer must perform a verified commissioning test following replacement of a system part.
- The maximum request rate supported is 32 kHz and 16 kHz for DRIVE-CLiQ.
- Electrical errors for the BiSS Safety serial interface are detected by the evaluation unit comparing CPW and SPW content. See the data sheet *BiSS Safety for RESOLUTE and FORTiS encoders* (Renishaw part no. L-9517-9884) for more information.
- Electrical errors for the Siemens DRIVE-CLiQ serial interface are detected by the evaluation unit comparing POS1 and POS2 content. See the relevant Siemens AG evaluation unit manual for more information.
- When installed correctly, the FORTiS-N FS encoder, with or without mounting spar, has a mechanical safe position of ± 1 mm.

5.1 Fault exclusions

The following will invalidate the Functional Safety certification of the FORTiS-N FS encoder system:

- Faults caused by cutting and reconnecting the cable or the use of a non-Renishaw cable that is not approved.
- Incorrect installation.
- Dismantling.
- Operating the system outside the limits specified in this installation guide.

5.2 Failure modes effects and diagnostics analysis

All diagnosed failure modes are detected immediately except for a position discrepancy between the two measurement methods which is detected within 375 μ s.

See [section 4](#) on page 10 for a summary of the FMEDA.

NOTE: For the purposes of the FMEDA calculation the following conditions have been assumed:

Method: SN29500-2005-1 **Environment:** Ground mobile **Temperature:** 60 °C

5.3 Installation

For the safety function to be valid the instructions detailed in this installation guide must be followed.

5.4 Commissioning test

The following test **MUST** be performed when commissioning the FORTiS-N FS encoder system and after any repair or maintenance of the system.

Resolution check

Move the axis by a known distance and confirm that the position changes as expected. The tolerance for raising a fault condition is relative to the safe position determined by the system manufacturer.

5.5 Evaluation unit monitoring

To achieve full system integrity the evaluation unit must continuously monitor the error condition of each readhead in the FORTiS-N FS encoder system, and in the case of fault detection place the system into a safe state within the process safety time.

NOTES:

1. The evaluation unit must have its Functional Safety functions enabled (as often it is a configuration parameter to turn on Functional Safety functionality) and must respond correctly to a FORTiS-N FS encoder system position error flag.
 2. A persistent fault condition may indicate a hardware failure of the FORTiS-N FS encoder system or an installation problem.
-

5.6 Maintenance

The maintenance check intervals will be defined by the system manufacturer according to their risk assessment. There are no user-serviceable parts within the FORTiS-N FS encoder system.

The following maintenance actions are advised:

- Check the extrusion screws and readhead retaining screws are correctly tightened.
- Check for worn or damaged cables and connectors.
- Check the cable connectors are correctly tightened/located.
- Check the air supply fitting is correctly tightened and the air hose is correctly fitted.
- When the DRIVE-CLiQ interface is used check the retaining screws are correctly tightened.

5.7 Repair

- Repair of the FORTiS-N FS encoder system is only by replacement of parts.
- The replacement parts must have the same part number as the original parts.
- The repaired encoder system must be installed and commissioned in accordance with “Commissioning test” on page 11.
- In the event of failure the affected parts should be returned to Renishaw for further analysis.
- Using damaged parts invalidates the Functional Safety certification.

5.8 Proof testing

It is the responsibility of the system manufacturer to define any proof testing of the system. Due to the diagnostic coverage (DC) and safe failure fraction (SFF) required to achieve SIL2, the encoder can only support continuous demand use.

6 Certification

FORTiS-N FS encoder system

Functional Safety Certificate No. FSC003



Under the terms of CSA SIRA Functional Safety Certificate SIRA CASS0023/02, for the management and self-certification of functional safety activities up to SIL3/PLd.

Renishaw plc declares that the products listed by this installation guide meet the requirements of:

- IEC 61508-1:2010, IEC 61508-2:2010 and IEC 61508-3:2010
- IEC 61800-5-2:2016
- ISO 13849-1:2015 and ISO 13849-2:2012

when used as an element/subsystem in safety-related systems performing safety functions requiring up to and including:

- SIL2 with HFT = 0 (1oo1)
- Category 3, PLd.

7 Summary of EU declaration of conformity EUD 2021-00819

EU based person authorised to compile the technical file: Renishaw (Ireland) DAC, Swords Business Park, Swords, Co. Dublin, K67 FX67, Ireland.

This declaration of conformity is issued under the sole responsibility of the manufacturer, Renishaw plc. The object of the declaration is identified below:

Product name:	FORTiS-S™ FS and FORTiS-N™ FS enclosed encoder system	
Description:	Enclosed linear FS readhead and scale assembly	
Part no.:	Valid from:	Description:
FS1-----S----	-02	FORTiS-S™ FS standard size enclosed linear encoders
FN1-----S----	-02	FORTiS-N™ FS narrow size enclosed linear encoders

The object of the declaration described above is in conformity with all relevant EU harmonisation legislation and fulfils all the relevant provisions with EU directives:

2006/42/EC	Machinery Directive
2014/30/EU	Electromagnetic Compatibility (EMC)
2011/65/EU	On the restriction of the use of certain hazardous substances in electrical and electronic equipment – RoHS

and complies with the following technical standards:

EN ISO 12100:2010	Safety of machinery – General principles for design – Risk assessment and risk reduction
EN ISO 13849-1:2015	Safety of machinery – Safety-related parts of control systems Part 1: General principles for design (ISO 13849-1:2015)
EN ISO 13849-2:2012	Safety of machinery – Safety-related parts of control systems Part 2: Validation (ISO 13849-2:2012)
EN 61326-1:2013	Electrical equipment for measurement, control, and laboratory use. EMC requirements Part 1: General requirements
EN 62471:2008	Photobiological safety of lamps and lamp systems
EN IEC 63000:2018	Technical documentation for the assessment of electrical and electronic products with respect to the restriction of hazardous substances

For the full Declaration of Conformity EUD 2021-00819 see:

www.renishaw.com/productcompliance

8 Summary of UK declaration of conformity UKD 2021-00819

This declaration of conformity is issued under the sole responsibility of the manufacturer, Renishaw plc. The object of the declaration is identified below:

Product name:	FORTiS-S™ FS and FORTiS-N™ FS enclosed encoder system		
Description:	Enclosed linear FS readhead and scale assembly		
Part no.:	Valid from:	Description:	
FS1-----S----	-02	FORTiS-S™ FS standard size enclosed linear encoders	
FN1-----S----	-02	FORTiS-N™ FS narrow size enclosed linear encoders	

The object of the declaration described above is in conformity with all relevant UK Statutory Instruments (and their amendments):

S.I. 2008 No. 1597	Supply of Machinery (Safety) Regulations 2008
S.I. 2016 No. 1091	Electromagnetic Compatibility Regulations 2016
S.I. 2012 No. 3032	The Restriction of the Use of Certain Hazardous Substances in Electrical and Electronic Equipment Regulations 2012 – RoHS

and complies with the following technical standards:

EN ISO 12100:2010	Safety of machinery – General principles for design – Risk assessment and risk reduction
EN ISO 13849-1:2015	Safety of machinery – Safety-related parts of control systems Part 1: General principles for design (ISO 13849-1:2015)
EN ISO 13849-2:2012	Safety of machinery – Safety-related parts of control systems Part 2: Validation (ISO 13849-2:2012)
EN 61326-1:2013	Electrical equipment for measurement, control, and laboratory use EMC requirements Part 1: General requirements
EN 62471:2008	Photobiological safety of lamps and lamp systems
EN IEC 63000:2018	Technical documentation for the assessment of electrical and electronic products with respect to the restriction of hazardous substances

For the full declaration of conformity UKD 2021-00819 see:

www.renishaw.com/productcompliance

9 Overview of the FORTiS-N FS encoder system









This system is an enclosed linear optical encoder designed for use in harsh industrial environments where high-precision feedback and metrology are required. Based upon Renishaw's award-winning absolute technology, the rugged non-contact design has no internal moving parts, such as bearings or wheeled readhead carriages, thus improving the overall reliability. Additionally, hysteresis and backlash errors associated with mechanical contact system designs are reduced.

In addition to enhanced breakage resistance, the robust steel scale has a coefficient of thermal expansion similar to the base material used in the majority of machines, reducing errors due to thermal effects whilst increasing measurement certainty.



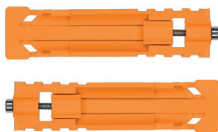



Renishaw's patented set-up LED provides instant verification of the encoder's signal strength and therefore its accurate alignment. This intuitive procedure eliminates the need for additional peripheral diagnostics equipment during installation. When combined with Renishaw's carefully designed installation accessories, these unique tools make installation easier and faster compared to traditional methods, whilst building confidence in a right-first-time installation.

10 Parts list

10.1 Included in the box

Item		Description
	FORTIS-N FS encoder unit	The FORTIS-N FS enclosed encoder unit
	18 mm readhead setting shim	Plastic shim to be used as an installation aid
	Air connection fitting	To enable connection to one of the encoder air purge inlets
	Cable connection wrench	Used for securely connecting the encoder cable to the readhead
	Alignment brackets	Two brackets to secure the readhead during transit and set the correct readhead alignment during installation <hr/> IMPORTANT: Retain until installation is complete <hr/>
	Serrated washers	2 × M8 serrated washers for mounting an extrusion with standard end caps
	Serrated washers	2 × M4 serrated washers for mounting the readhead to the machine slideway
	FORTIS-N FS quality inspection certificate	Certifies specific encoder performance and provides traceability
	Yellow Functional Safety card	Shows the web address for accessing the installation guide
	Siemens DRIVE-CLiQ interface	Included with Siemens-only versions of FORTIS (see section 16.4 on page 44)

10.2 Not included / required tools

Item		Description
	6 mm torque wrench	To tighten the extrusion mounting screws
	3 mm torque wrench	To tighten the readhead mounting screws
	1.5 mm hex key	Air bung removal (only if air purge is required)
	3 mm hex key	For locking the mounting aid
	M8 screws	2 × M8 × 1.25 screws length ≥ 20 mm for mounting the extrusion
	M4 screws	2 × M4 × 0.7 screws length ≥ 20 mm for mounting the readhead
	Loctite 243	All fastenings (except air bung and cable connection) should be secured with Loctite 243
	Loctite 222	If an air bung requires replacement or repositioning it should be secured with Loctite 222. The cable connector should also be secured with Loctite 222.

10.3 Optional extras

10.3.1 Mounting aid (Renishaw part no. A-9768-3586)

Optional installation aid to assist with mounting the readhead to a machine slideway that has more than one degree of freedom (see [section 15.5](#) on page 35).

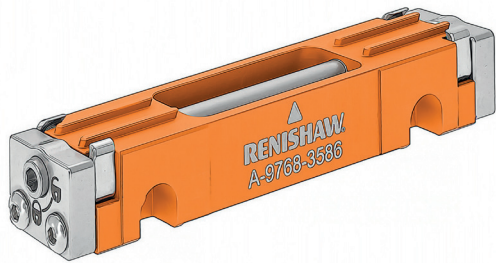



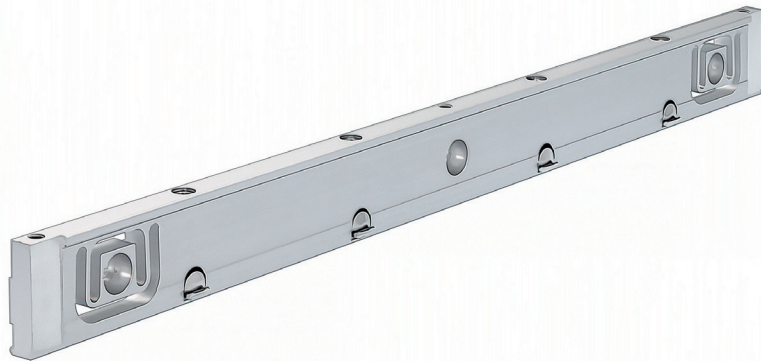

10.3.2 Mounting spar

For measuring lengths greater than 620 mm Renishaw recommends the use of a mounting spar (see [section 15.2](#) on page 30).



10.4 Cable options (cables not included)

Further information relating to cables for the FORTiS encoder range can be found in the data sheet *Cables for FORTiS absolute encoders* (Renishaw part no. L-9517-0069). This can be downloaded from our website www.renishaw.com/fortisdownloads and is also available from your local Renishaw representative.

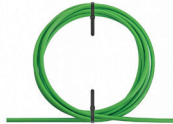
Item		Description
	Encoder cable type A	OD: 4.7 mm, 28 AWG, 7 core, single screen, black jacket Length options: 0.5 m, 1 m, 3 m, 6 m, 9 m
	Encoder cable type B	OD: 6.3 mm, 23 AWG, 6 core (3 × twisted pairs), single screen, green jacket Length options: 0.5 m, 1 m, 3 m, 6 m, 9 m
	Encoder cable type D	Armoured: OD 10 mm, 28 AWG, 7 core Length options: 1 m, 3 m, 6 m, 9 m
	Extension cable type B	OD: 6.3 mm, 23 AWG, 6 core (3 × twisted pairs), single screen, green jacket Length options: 1 m, 3 m, 6 m, 9 m, 15 m, 20 m
	Extension cable type C	OD: 7.8 mm, 2 × 20 AWG (power), 4 × 23 AWG (signal), 2 × 28 AWG (sense), single screen, green jacket Unterminated lengths available up to 100 m

10.4.1 FORTiS connector

All encoder cables include a custom FORTiS connector that connects to the readhead. The connector is covered with a protective cap with an integrated clip; this clip can be used to assist with cable routing.

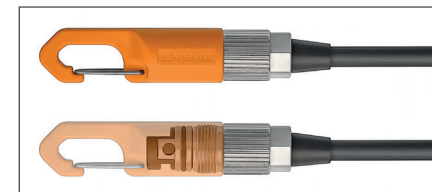

11 Storage and handling

IMPORTANT: Handle carefully to avoid damage to the location faces when unpacking and installing.

Storage temperature

-20 °C to +70 °C

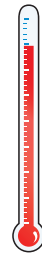

Operating temperature

0 °C to +50 °C

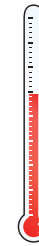

95% relative humidity (non-condensing)
to IEC 60068-2-78

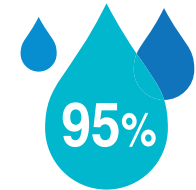

Handling instructions

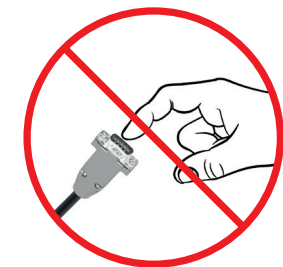
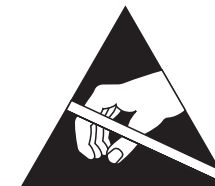
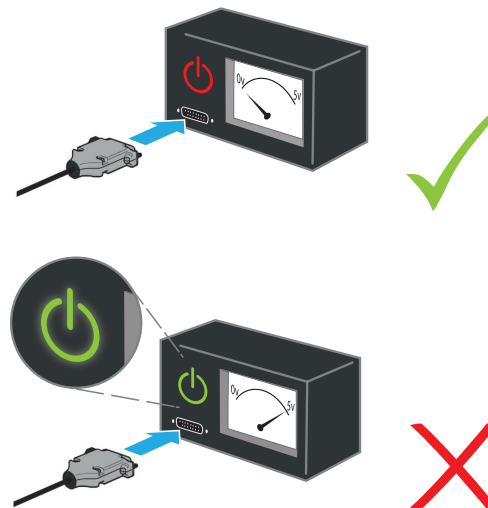
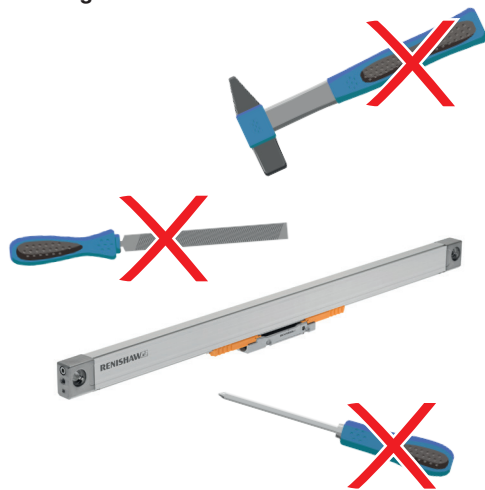

12 Installation drawings

12.1 Mounting surface preparation

To ensure correct operation, the mounting surface should be prepared as follows:

- surface flatness requirement of 0.05 mm/m
- surface should be free of paint and burrs
- refer to installation drawing for required mounting hole positions (see [section 12.5](#) on page 22).

To further simplify and help reduce installation time, it is recommended that the machine axis to which the encoder is to be mounted is prepared with a datum edge or aligned dowel pins to help locate the edge of the extrusion and ensure parallelism to the axis of motion.

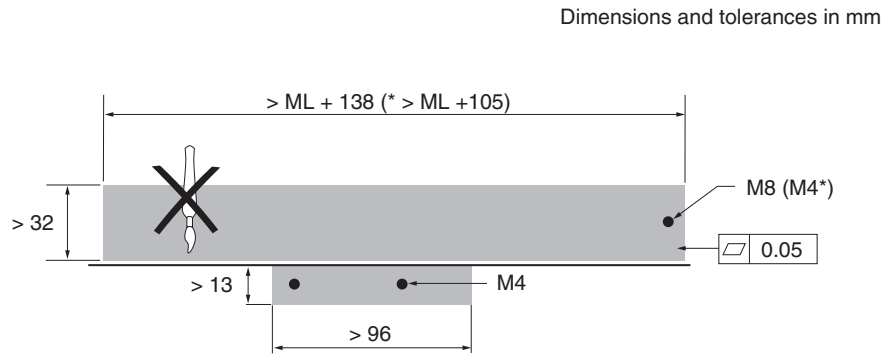

*M4 for short end cap version.

12.2 Datum location edge or dowel pins – standard end caps

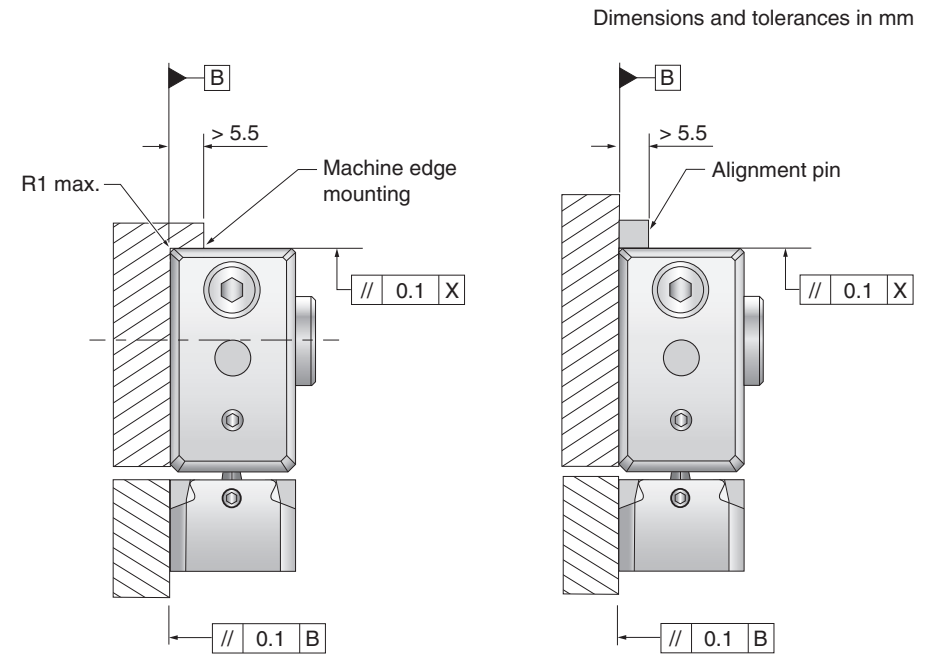

KEY

X = Machine guideway/axis datum

NOTES:

1. Side elevations show alternative mounting orientations.
2. Alignment pin and machine edge mounting options to mate directly to the top face of the extrusion.

12.3 Mounting orientations – standard end caps

Dimensions and tolerances in mm

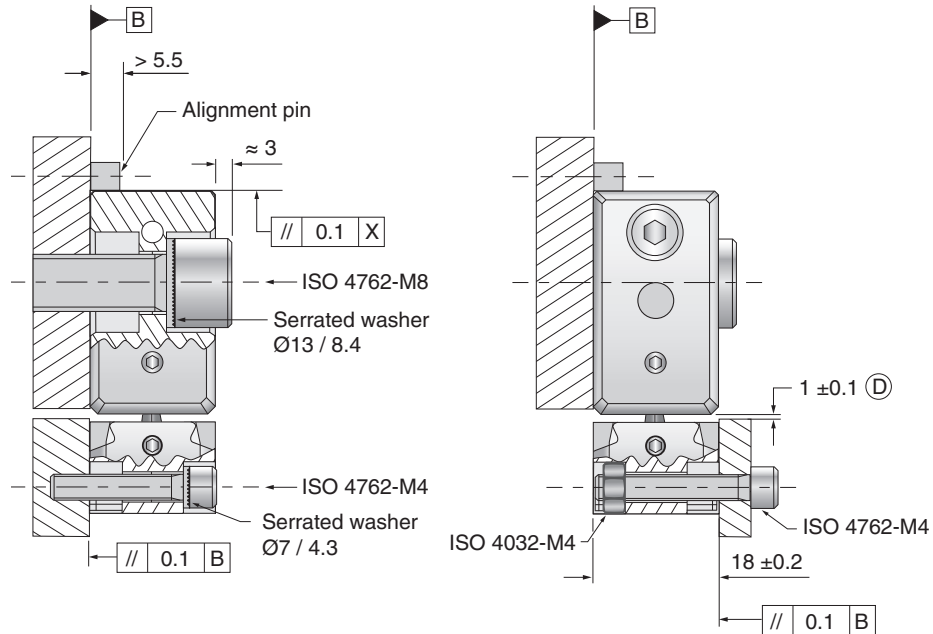

KEY

D = Required mounting dimensions

X = Machine guideway/axis datum

NOTES:

1. Side elevations show alternative mounting orientations.
2. Alignment pin and machine edge mounting options to mate directly to the top face of the extrusion.

12.4 Mounting orientations – short end caps

Dimensions and tolerances in mm

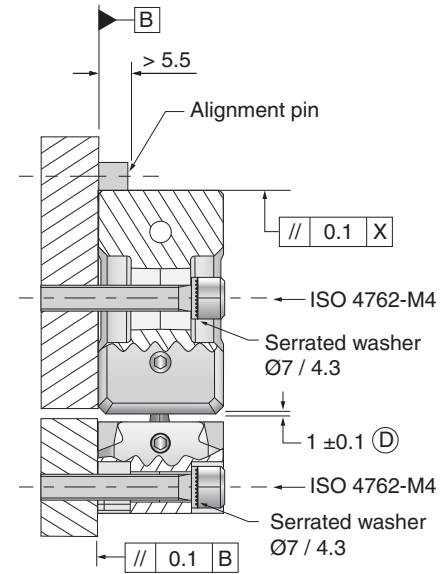

KEY

D = Required mounting dimensions

X = Machine guideway/axis datum

NOTES:

1. Side elevation shows alternative mounting orientation.
2. Extrusion mounting can be machine edge or dowel pins.

12.5 FORTiS system installation drawing – standard end caps (ML 320 mm shown)

Dimensions and tolerances in mm

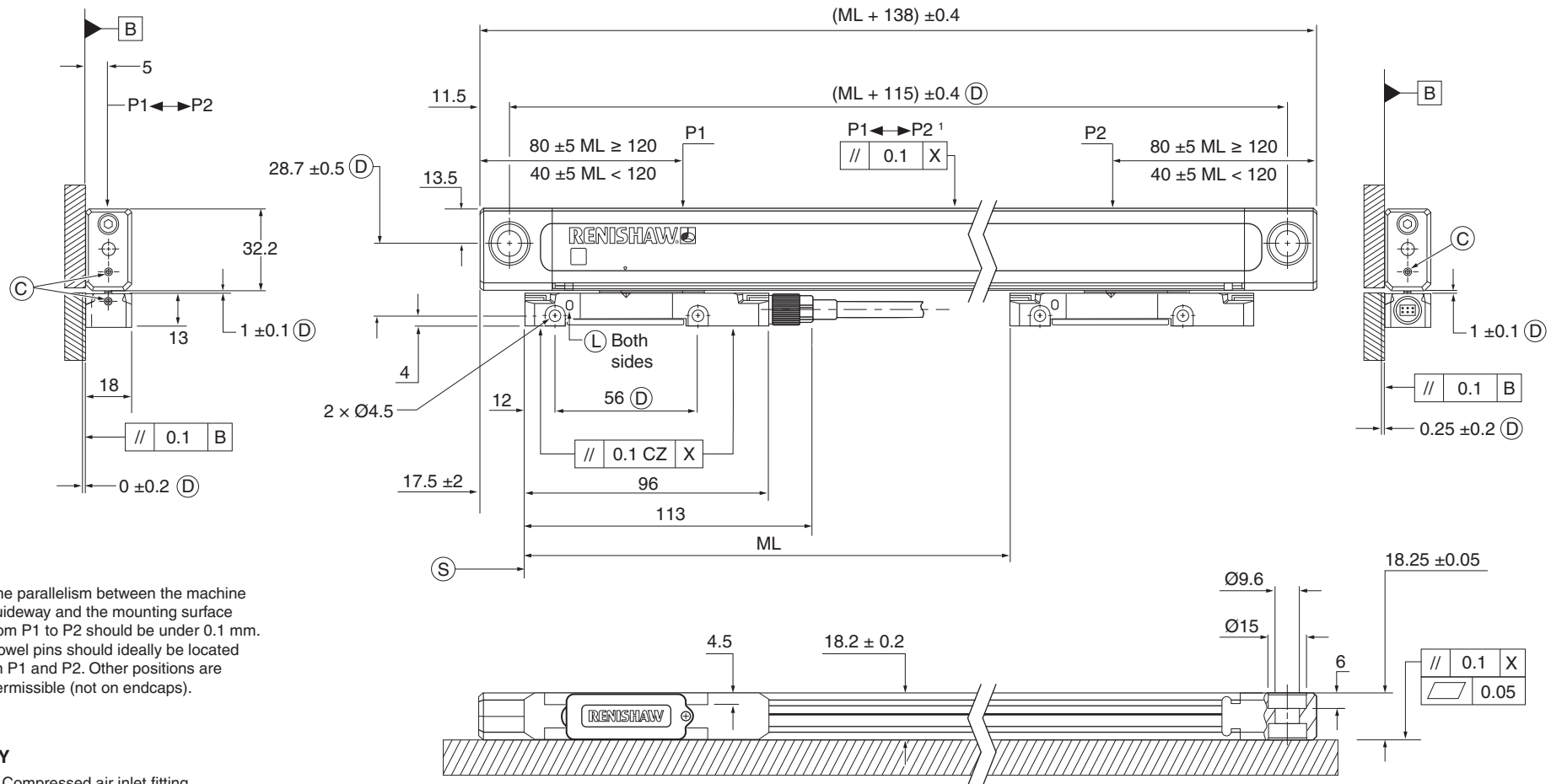

¹ The parallelism between the machine guideway and the mounting surface from P1 to P2 should be under 0.1 mm. Dowel pins should ideally be located on P1 and P2. Other positions are permissible (not on endcaps).

KEY

- C = Compressed air inlet fitting
- D = Required mounting dimensions
- L = LED set-up illumination
- ML = Measuring length
- P = Gauging points for alignment
- S = Start of measuring length
- X = Machine guideway/axis datum

ML	70	120	170	220	270	320	370	420	470	520	570	620	670	720	770	820	920	1020	1140	1240	1340	1440	1540	1640	1740	1840	2040
----	----	-----	-----	-----	-----	-----	-----	-----	-----	-----	-----	-----	-----	-----	-----	-----	-----	------	------	------	------	------	------	------	------	------	------

12.6 FORTiS system installation drawing – short end caps (ML 320 mm shown)

Dimensions and tolerances in mm

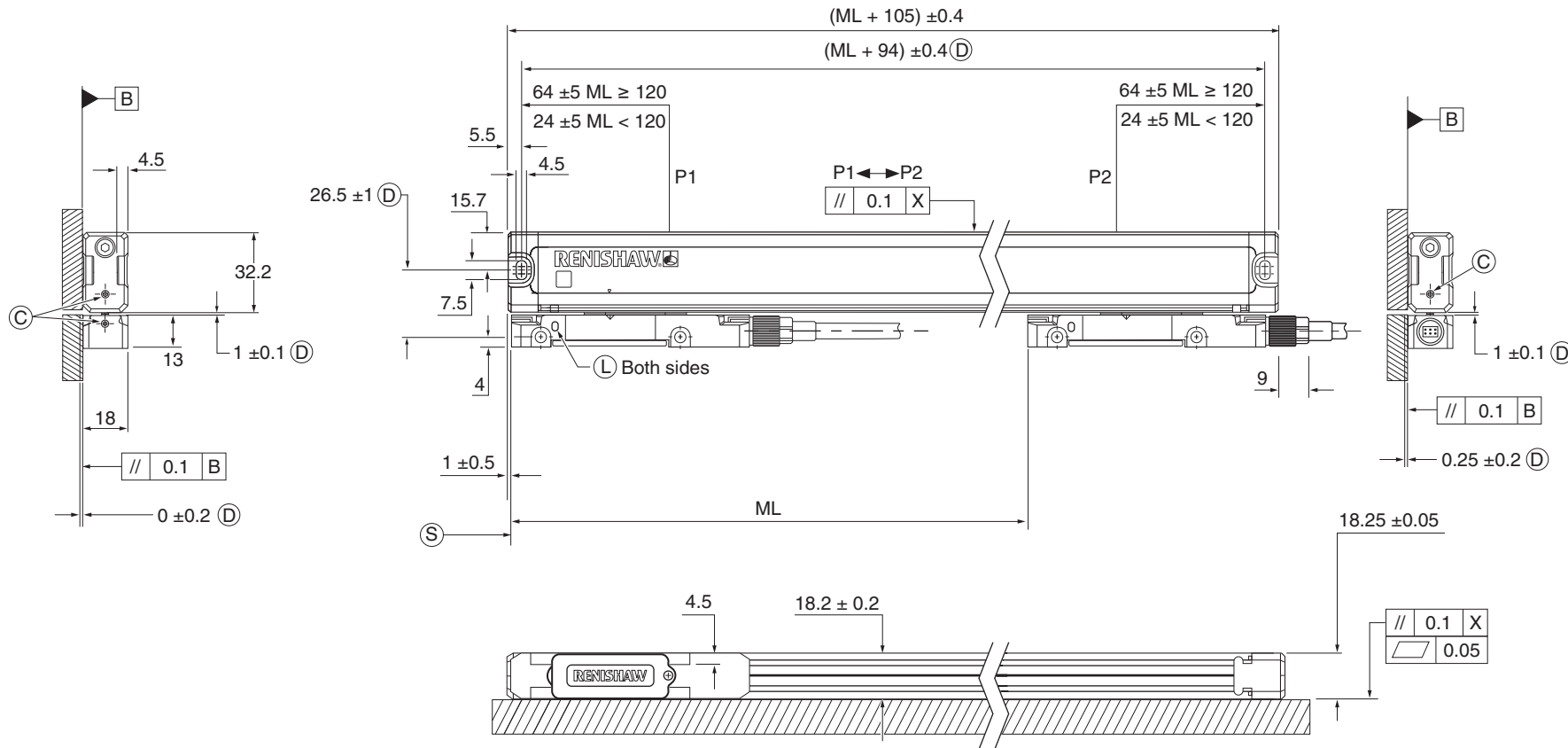

KEY

- C = Compressed air inlet fitting
- D = Required mounting dimensions
- L = LED set-up illumination
- ML = Measuring length
- P = Gauging points for alignment
- S = Start of measuring length
- X = Machine guideway/axis datum

ML	70	120	170	220	270	320	370	420	470	520	570	620	670	720	770	820	920	1020	1140	1240	1340	1440	1540	1640	1740	1840	2040
----	----	-----	-----	-----	-----	-----	-----	-----	-----	-----	-----	-----	-----	-----	-----	-----	-----	------	------	------	------	------	------	------	------	------	------

13 Product specification

Measuring standard	Renishaw stainless-steel scale with single track absolute encoding
Coefficient of thermal expansion (at 20 °C)	10.1 ±0.2 µm/m/°C
Thermal datum	At centre position (encoder position of 0.5 × measuring length)
Measuring lengths available (mm)	70, 120, 170, 220, 270, 320, 370, 420, 470, 520, 570, 620, 670, 720, 770, 820, 920, 1020, 1140, 1240, 1340, 1440, 1540, 1640, 1740, 1840, 2040 (mounting spar available – recommended for > 620 mm length)
Accuracy grades	High grade: ≤ ±3 µm Standard grade: ≤ ±5 µm
Resolution ¹	1 nm, 10 nm, 50 nm
Sub-Divisional Error (typical)	±40 nm
Jitter (RMS)	10 nm
Absolute position serial interface	BiSS Safety Siemens DRIVE-CLiQ (with external interface)
Encoder electrical connection	Cable connector M12 custom
Controller electrical connection	8-way M12, 9-way D-Type, flying lead
Cable length	See section 16.2 on page 40
Power supply	See section 16.3 on page 42 and section 16.4 on page 44
Set-up LED	See section 15.7 on page 38

¹ Resolution per accuracy grade and serial interface – standard options

Accuracy grade	Serial interface	Resolution
3 µm	BiSS Safety, Siemens DRIVE-CLiQ	1 nm
5 µm	BiSS Safety, Siemens DRIVE-CLiQ	10 nm
		50 nm

Maximum speed	4 m/s
Acceleration (readhead relative to scale)	< 200 m/s ² in measuring direction
Moving force (maximum force required to move the readhead through the seals)	< 4 N
Vibration (55 Hz to 2 000 Hz)	Readhead: < 300 m/s ² to IEC 60068-2-6 Housing without mounting spar: < 200 m/s ² to IEC 60068-2-6 Housing with mounting spar: < 300 m/s ² to IEC 60068-2-6
Shock 11 ms half-sine	< 300 m/s ² IEC 60068-2-27
Operating temperature	0 °C to 50 °C
Storage temperature	–20 °C to 70 °C
Environment protection	IP53 when installed correctly, IP64 with air purge Protection class III Pollution degree II Altitude 2000 m
EMC immunity	IEC 61800-5-2:2016 <i>Electromagnetic immunity requirement for safety related systems – Annex E, second environment</i>
Air purge requirements	Air supply pressure = 1 bar at encoder At correct supply pressure the supplied air connection fitting restricts the air flow rate to 2 l/min Air quality: see section 15.8 on page 39 for details
Weight	0.11 kg + 0.45 kg/m

IMPORTANT: Specifications are subject to the correct installation procedures as set out in this installation guide. If in doubt, contact your local Renishaw representative.

14 Installation procedure – extrusion

Please note that fitment of the extrusion is independent of readhead mounting. For illustrative purposes, a datum edge is displayed, but the procedure is identical for dowel pins. Where neither an edge or dowel pins are available, begin by aligning the extrusion mounting holes.

NOTES:

1. If a suitable reference edge or dowel pins are not available then we recommend that the extrusion is checked against a dial gauge to ensure parallelism to the machine axis.
2. For measuring lengths greater than 620 mm Renishaw recommends the use of a mounting spar (see [section 14.4](#) on page 27).
3. Ensure the mounting faces are clean before installation.

14.1 Protection for sealed linear encoders

IP53 requires installation with sealing lips positioned away from splash water in accordance with EN 60529/IEC 60529. For ingress protection to IP64, please see [section 15.8](#) on page 39.

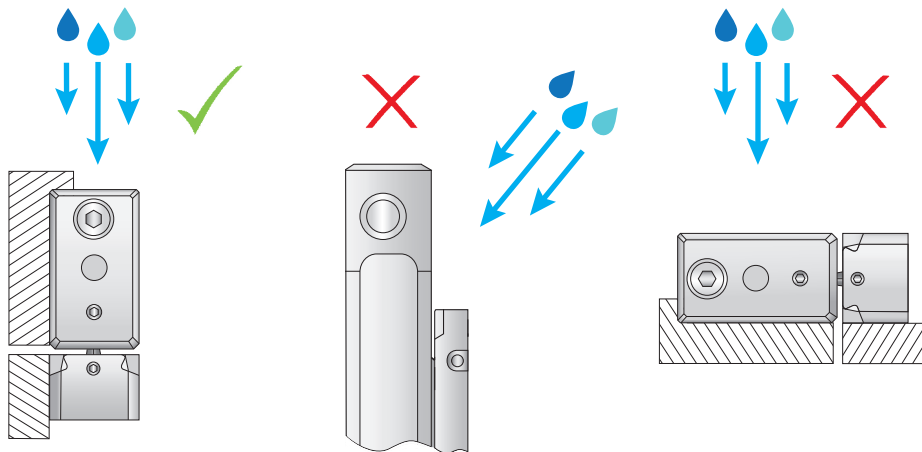

14.2 Thermal datum

The thermal datum of the encoder is located centrally. The coefficient of thermal expansion (CTE) of the encoder is $10.1 \pm 0.2 \mu\text{m}/^\circ\text{C}$.

The standard end cap version is mounted using two M8 screws; a high clamping torque of 20 Nm enables the extrusion to follow the expansion of the mounting surface material.

For measuring lengths > 620 mm a mounting spar is recommended; please refer to [sections 14.4](#), [14.5](#) and [14.6](#) for full details. (If required, a mounting spar can be used for measuring lengths under 620 mm.) The aluminium mounting spar's fixed central mounting hole provides a centrally located thermal datum position. The other mounting positions use flexures to allow the spar to effectively float over the machine's surface, ensuring reproducible thermal behaviour.

A short end cap version is recommended for use with the mounting spar.

NOTE: If the short end cap version of the encoder is installed directly onto a different mounting surface using two M4 screws without using the mounting spar, its thermal datum properties will be compromised.

14.3 Extrusion installation without mounting spar

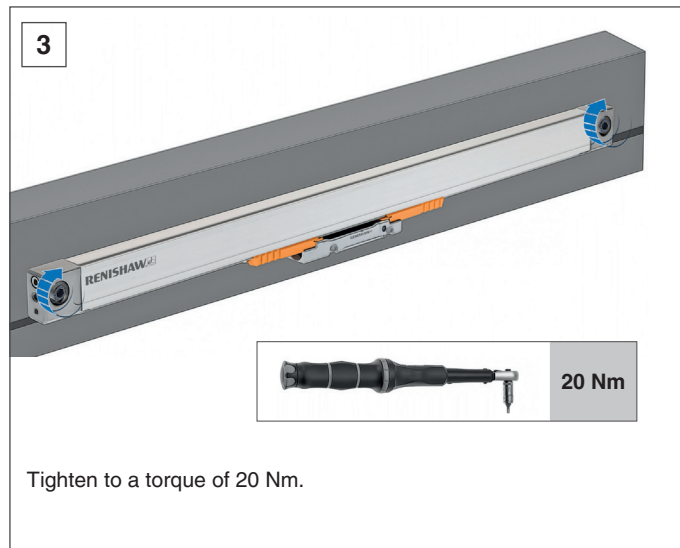
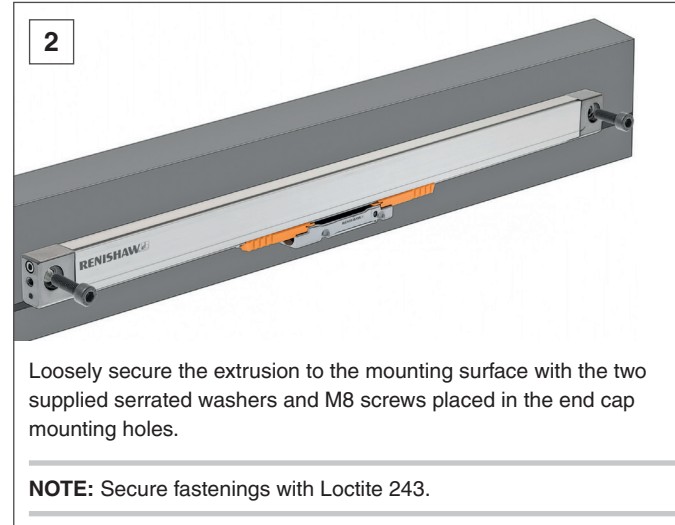
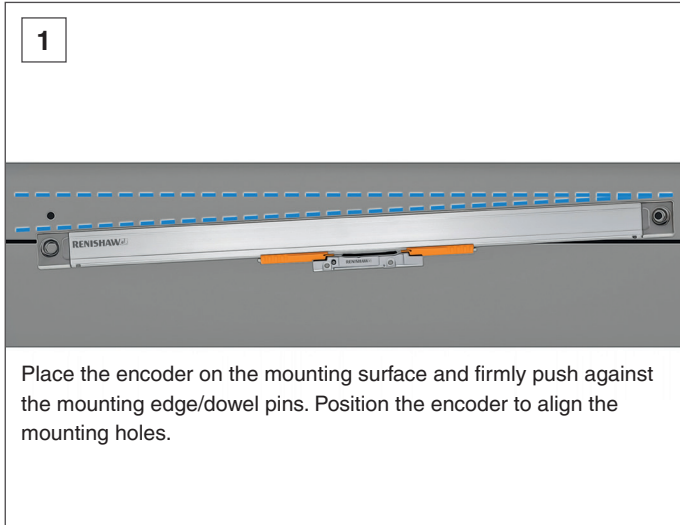

14.4 Installation with mounting spar

Renishaw recommends the use of a mounting spar where measuring lengths are greater than 620 mm. This requires encoders with short end caps. Where measuring lengths are less than 620 mm, if short end caps are specified, the mounting spar should also be used. If in doubt, please contact your local Renishaw representative.

The spar should be installed prior to fitting the encoder.

NOTE: Secure fastenings with Loctite 243.

1

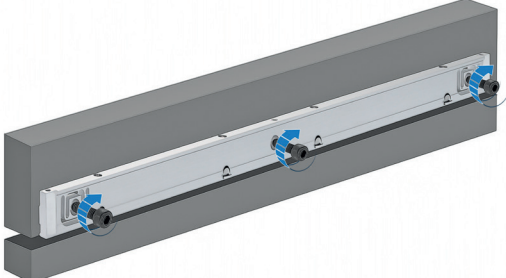

Place the mounting spar on the mounting surface and firmly push against the mounting edge/dowel pins. Position the spar to align to the surface mounting holes. Loosely secure the mounting spar to the mounting surface with appropriate M6 screws.

NOTE: Secure fastenings with Loctite 243.

2

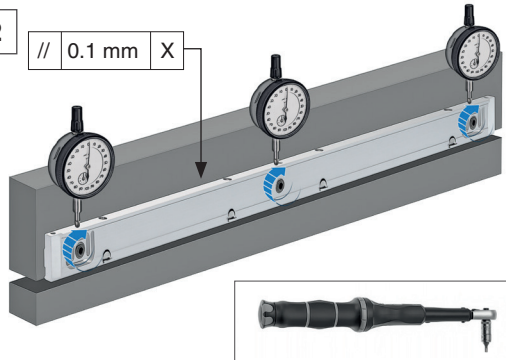

// 0.1 mm X

Use a dial gauge to ensure the mounting spar is set to the correct parallelism compared to the machine guideway. Once aligned tighten the screws to a torque of 8 Nm.

X = Machine guideway axis/datum.

3

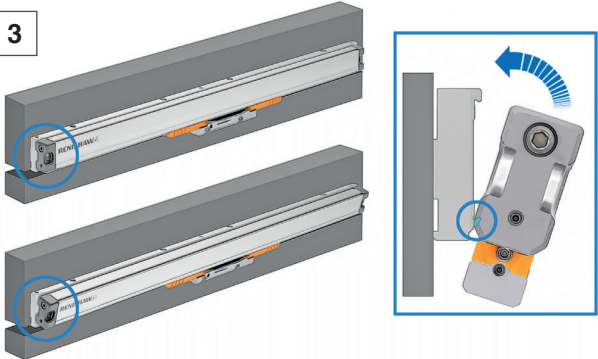

Position the encoder against the spar.

Inset: Ensure the clips on the mounting spar engage correctly with the extrusion profile.

4

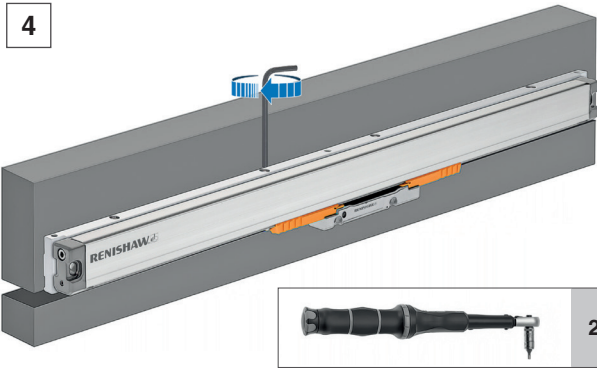

Tighten the screws on the top of the mounting spar to secure the encoder firmly to the mounting spar.

Tighten all bolts, working from left to right.

14.5 Mounting spar installation drawing (ML 620 mm shown)

Dimensions and tolerances in mm

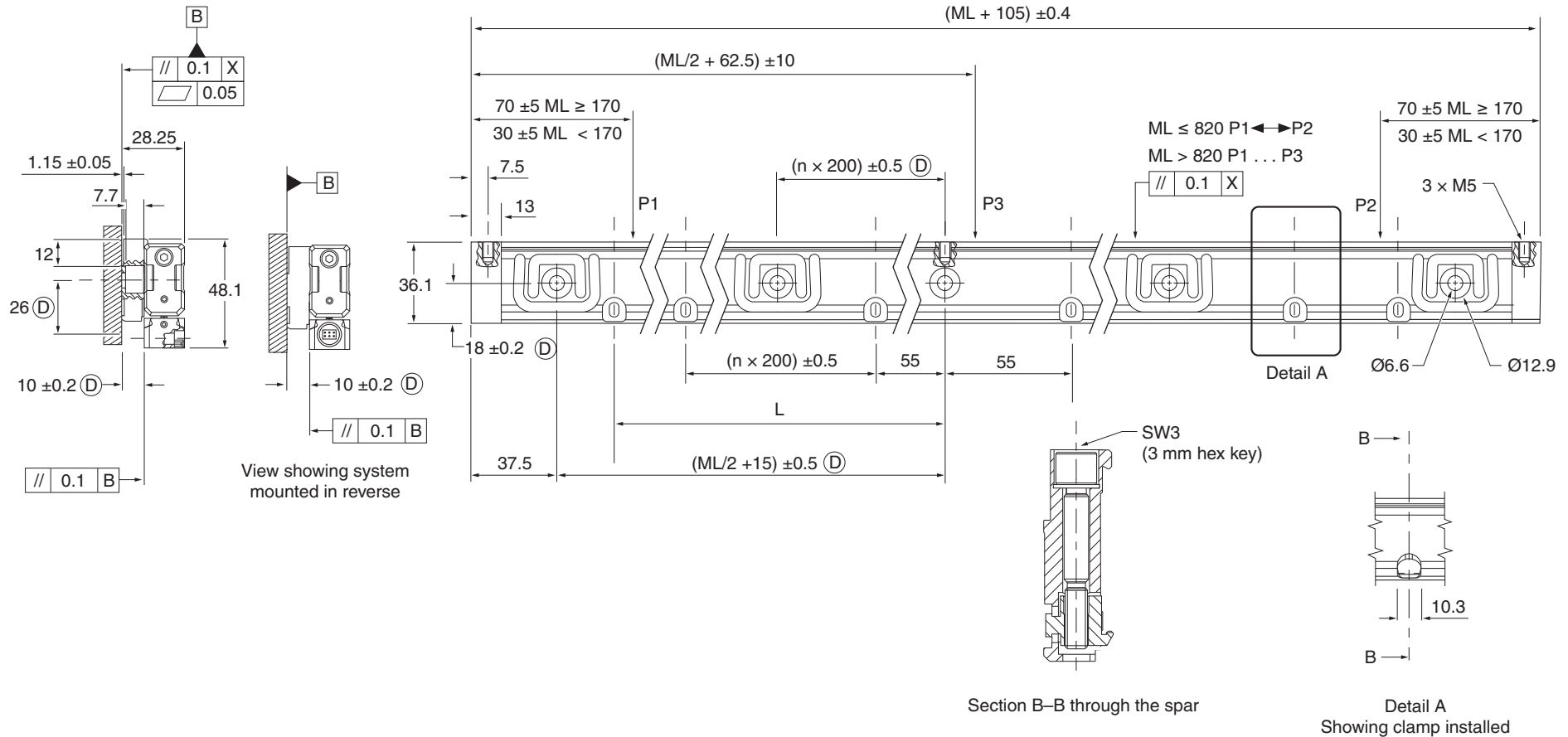

KEY

- D = Required mounting dimensions
- ML = Measuring length
- P = Gauging points for alignment
- X = Machine guideway/axis datum

ML	70	120	170	220	270	320	370	420	470	520	570	620	670	720	770	820	920	1020	1140	1240	1340	1440	1540	1640	1740	1840	2040
L	37.5	55	75	100	115	140	175	200	225	250	275	300	325	350	375	400	450	500	550	640	655	710	760	810	855	910	1010
n	-	-	-	-	-	-	-	-	-	-	-	1	1	1	1	1	1	2	2	2	2	3	3	3	3	4	4

14.6 Spar mounting options

Dimensions and tolerances in mm

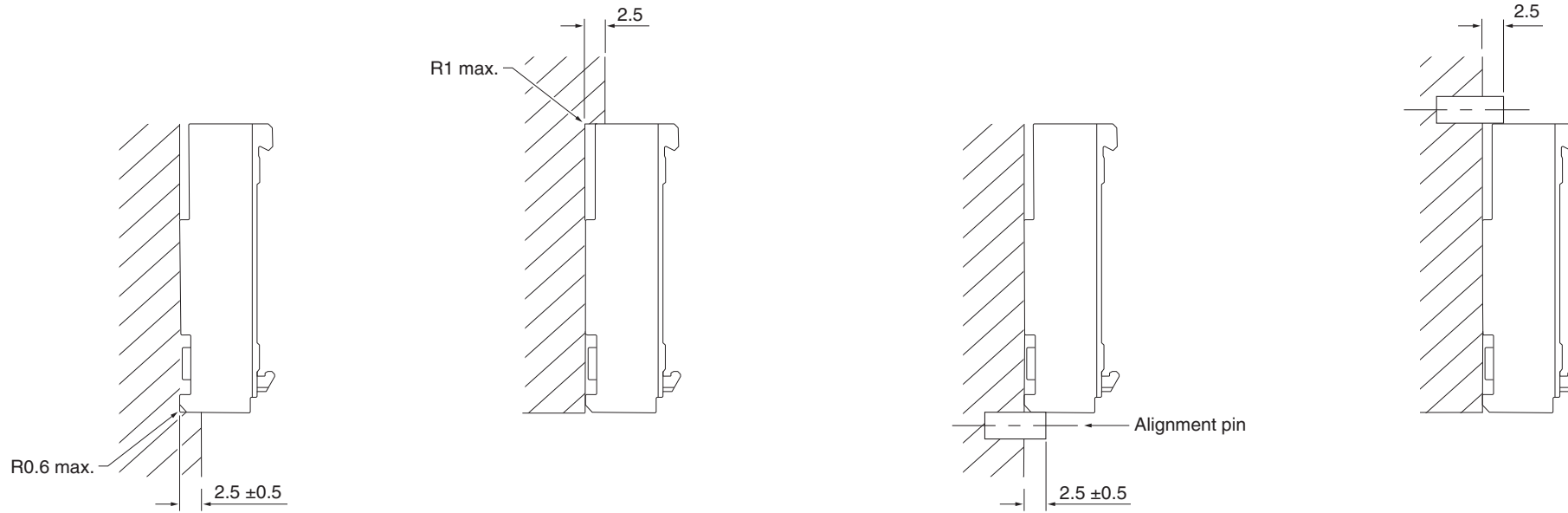

15 Installation procedure – readhead

Three different methods may be used to install the readhead, making installation easier for a wide range of machine types and mounting surfaces. These are outlined in the following sections.

NOTE: Installation of the extrusion follows the procedure outlined in [section 14](#) on page 25 and is independent of the readhead installation method being used.

15.1 Start of measuring length – standard

The start of the measuring length (ML) is indicated by the triangular marking on the extrusion; a corresponding arrow on the readhead should be aligned to this arrow to ensure the readhead is within the encoder measuring length.

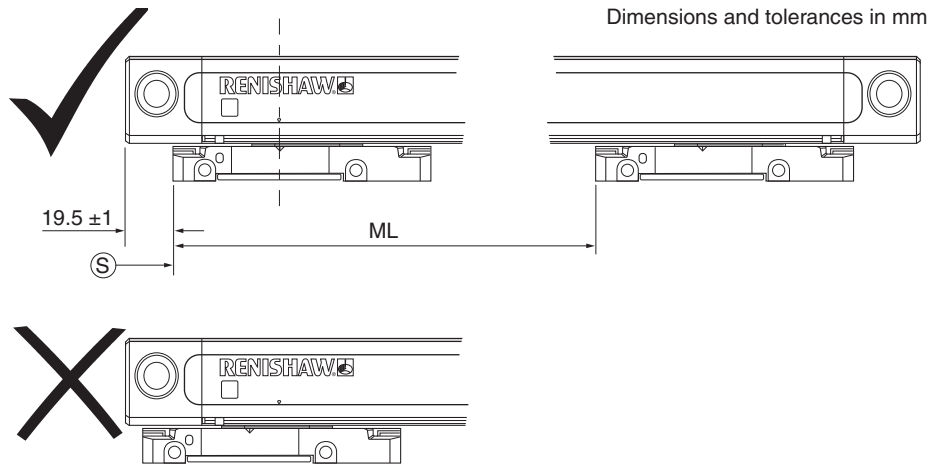

KEY

ML = Measuring length

S = Start of measuring length

WARNING: Failure to ensure the readhead is within the measuring length of the encoder could lead to a collision and damage.

15.2 Start of measuring length – short end caps

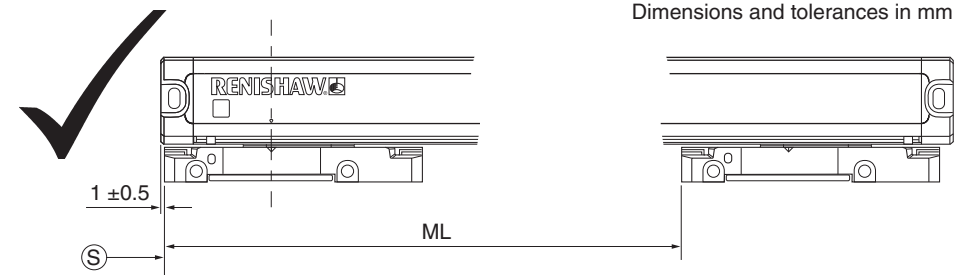

KEY

ML = Measuring length

S = Start of measuring length

15.3 Alignment bracket method

Pre-fitted alignment brackets help protect and secure the readhead to the extrusion during transit. These alignment brackets can also be used to set the readhead at the nominal installation rideheight and remain in place during installation.

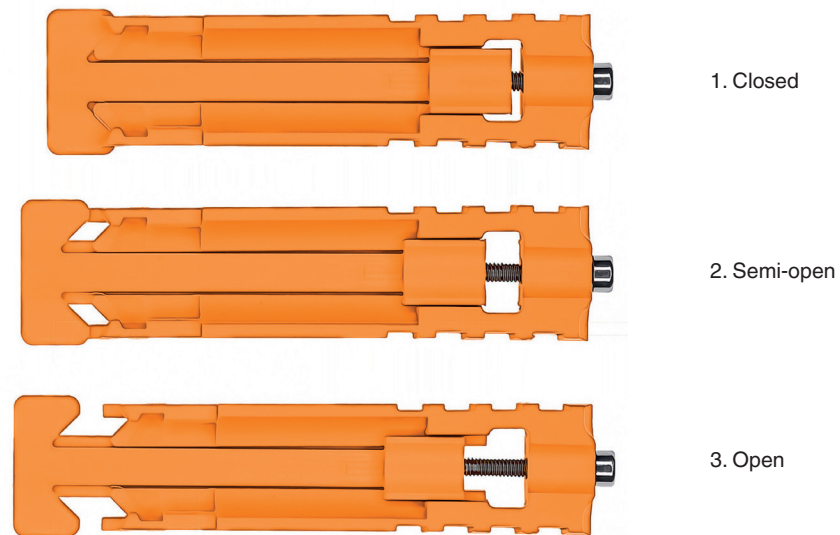

The alignment bracket can be loosened to allow position adjustment of the readhead (whilst maintaining the correct rideheight) by loosening the M2.5 screw at the end of the bracket. The alignment brackets must be fully removed following installation.

NOTE: This method cannot be used if an armoured cable is fitted, due to space restrictions.

15.3.1 Installation using the alignment bracket method

1

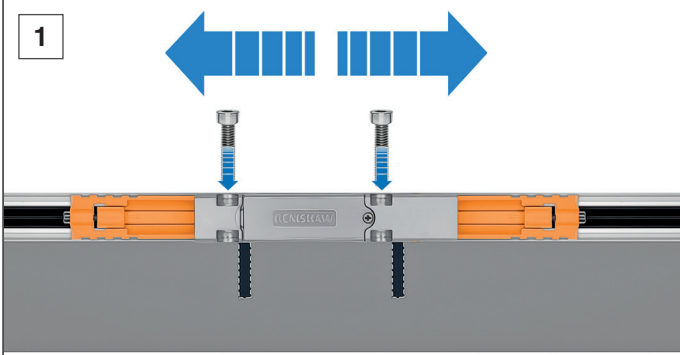

Align the readhead mounting holes to the machine slideway mounting holes.

Loosen the transit brackets enough to be able to move the readhead up and down the extrusion. Align the readhead mounting holes to the machine slideway mounting holes.

2

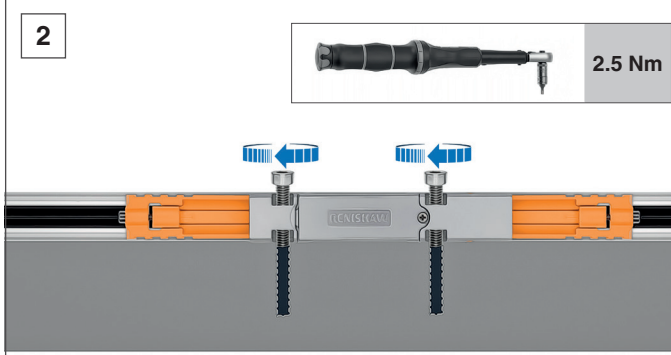

Secure the readhead to the machine slideway with the two supplied serrated washers and M4 screws placed in the end cap mounting holes. Tighten the screws to a torque of 2.5 Nm.

NOTE: Secure fastenings with Loctite 243.

3

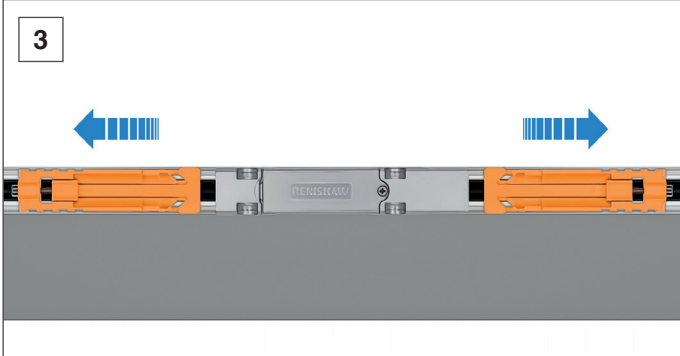

Remove the alignment brackets from the readhead and lift off the extrusion.

4



IMPORTANT: The alignment brackets must be removed after installation.

15.4 Set-up shim method 15.4.1 Front setting shim procedure

When using this method, remove the alignment brackets (see [section 15.3](#) on page 31) just prior to installation.

Where access to the readhead from either side is restricted in the installation position, a set-up shim can be used instead of the alignment brackets to ensure correct positioning of the readhead relative to the extrusion. The shim is easily inserted between the readhead and encoder extrusion.

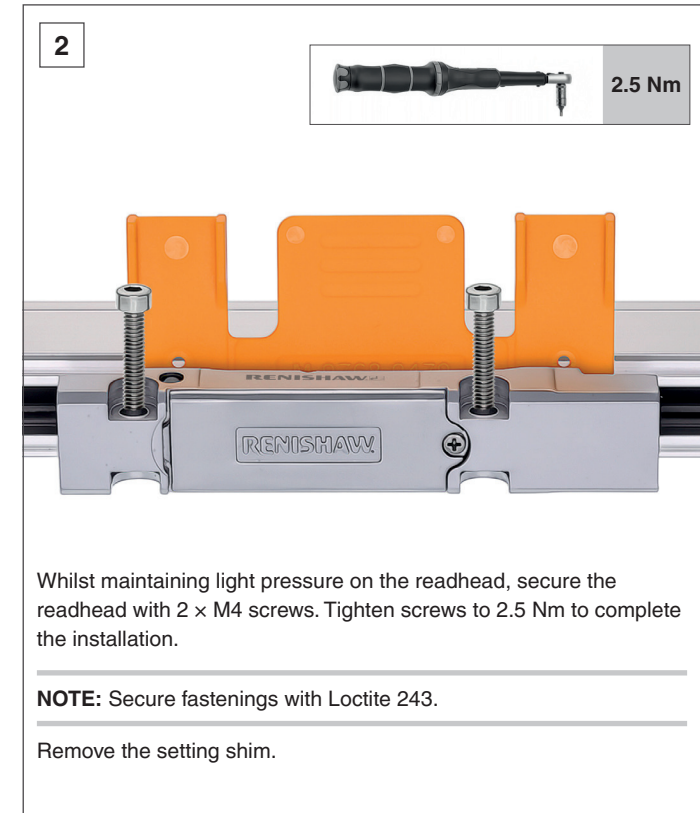
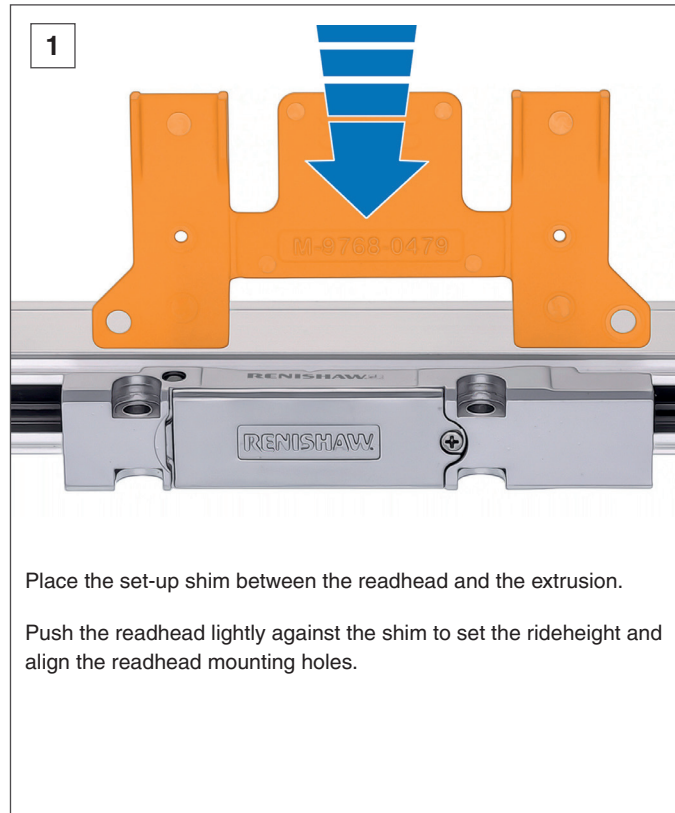

15.4.2 Side setting shim procedure

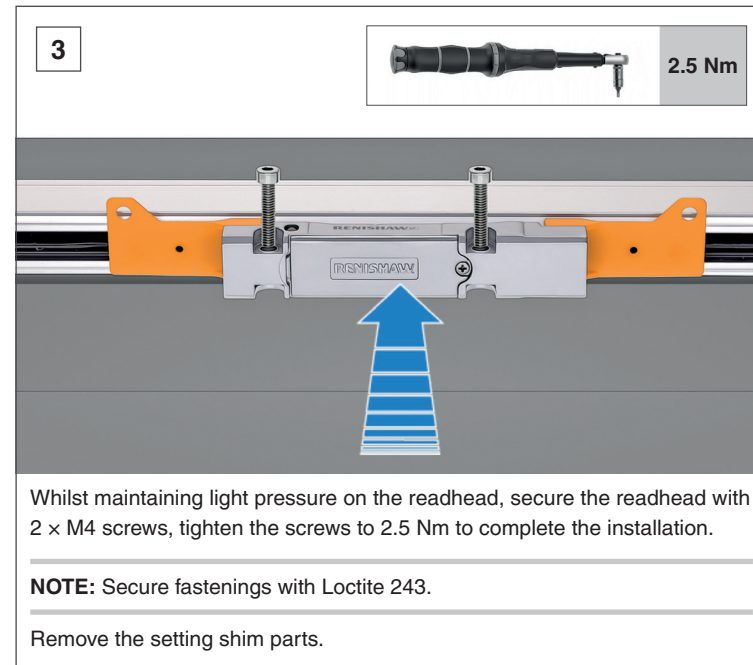
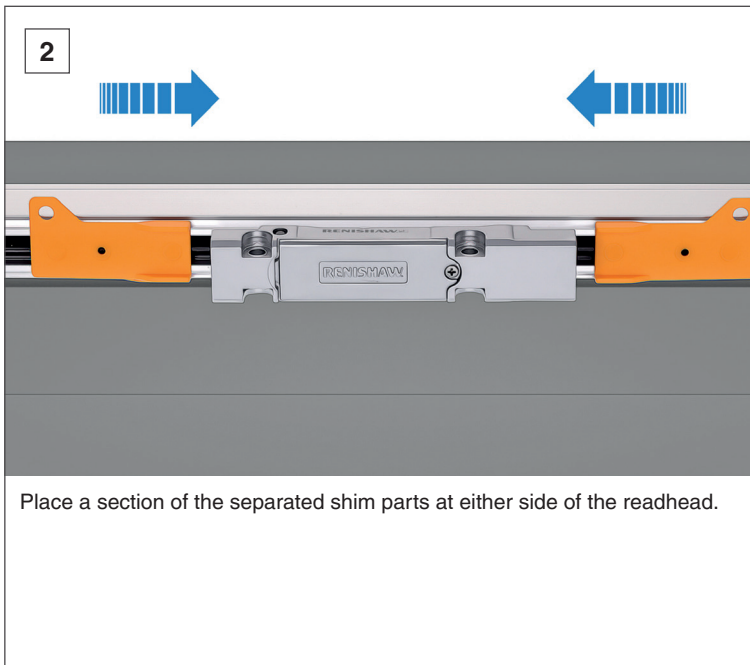
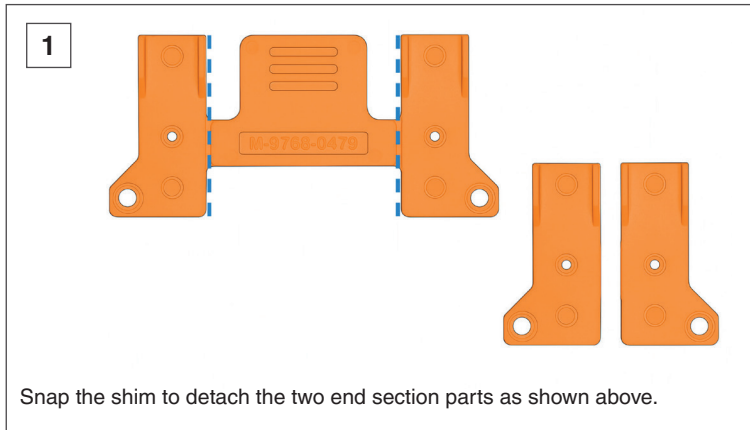

15.5 Installation using the mounting aid method

Remove the alignment brackets prior to installation using the setting shim.

When mounting a readhead to a machine slideway via an unconstrained bracket, an installation mounting aid can be used to accurately position, secure and fit the bracket to the slideway. The mounting aid clamps securely to the extrusion, allowing any machine slideway to be adjusted and secured horizontally in the correct location before readhead mounting.

NOTE: 18 mm mounting aid and 3 mm hex key required (see [section 10.3.1](#) on page 18).

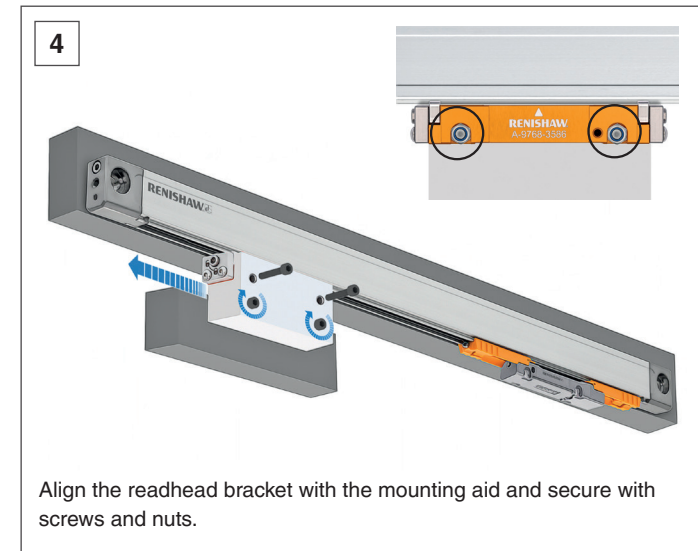
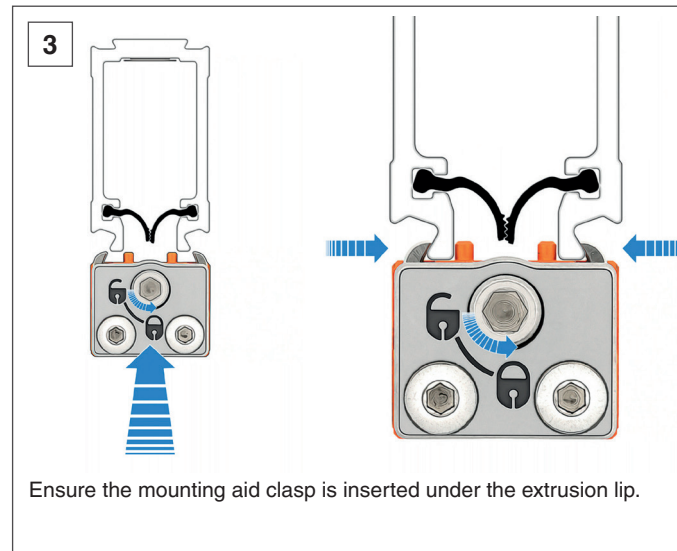
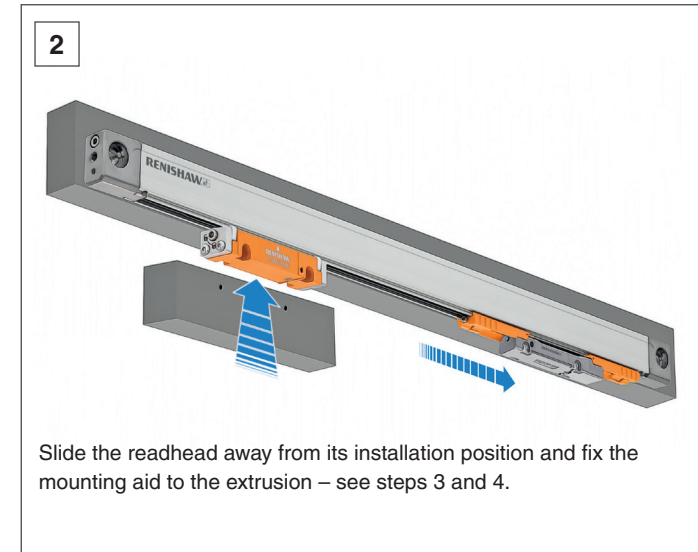
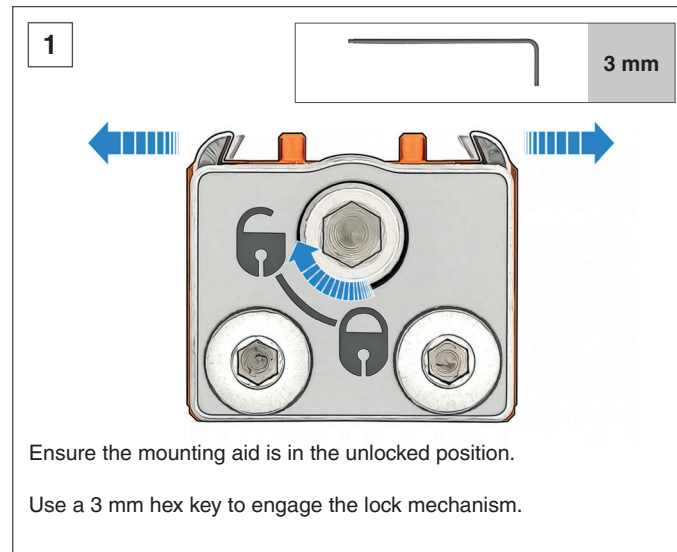

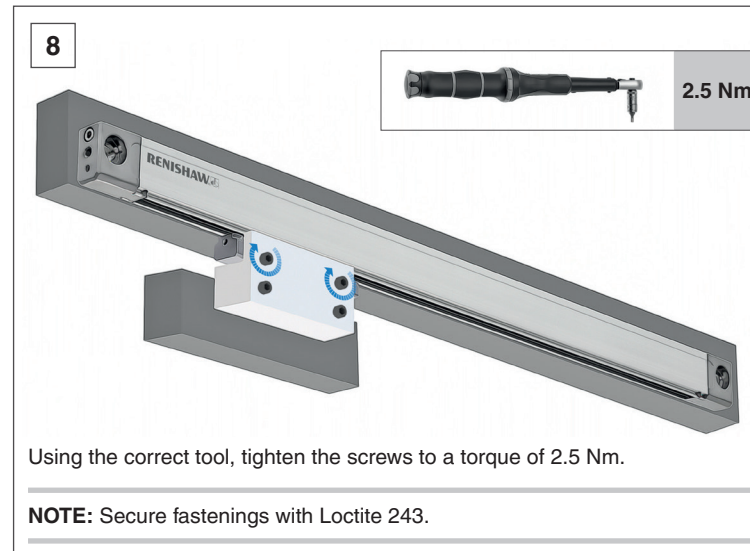
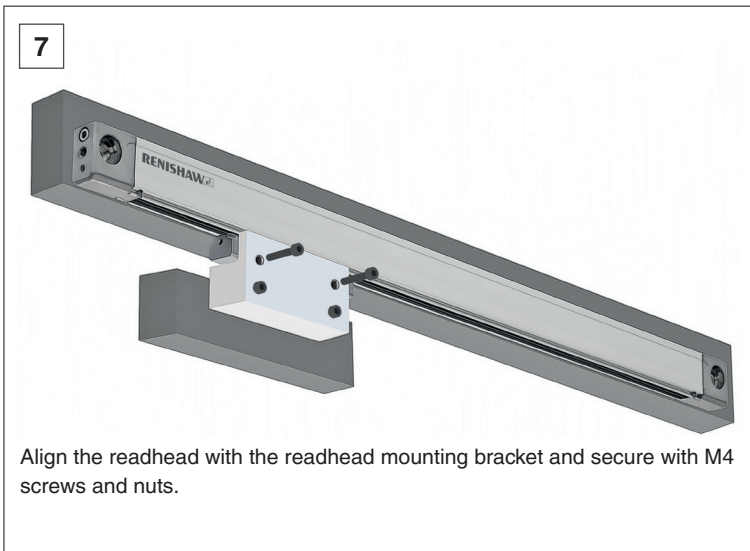
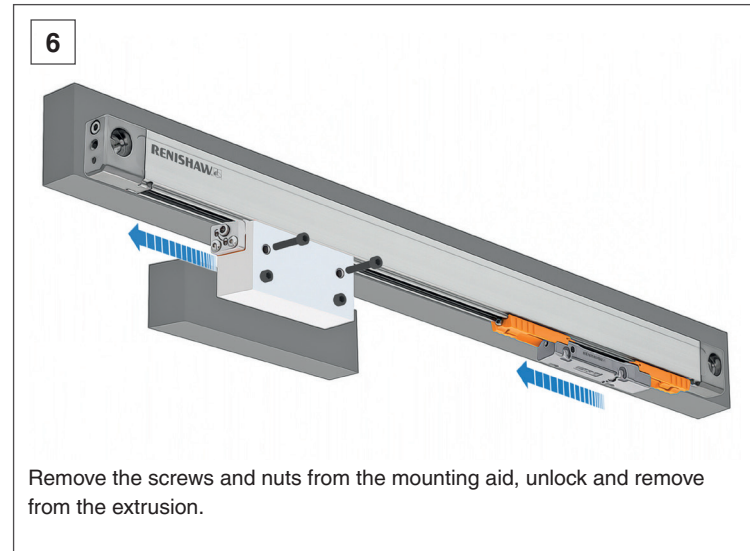
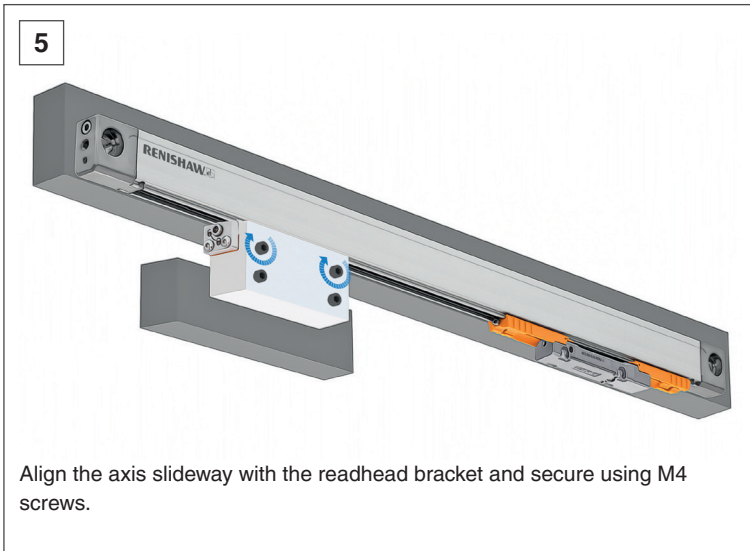

15.6 FORTiS cable connection

To assist with cable management the FORTiS-N system has a cable entry port, allowing the cable to be inserted into the side of the readhead.

The default cable port output direction is as per the installation drawing in [section 12](#) on page 20. If an alternative cable output port direction is needed please contact your local Renishaw representative.

NOTE – STEP 4:

Once the connector is engaged as shown, apply a further torque by hand on the knurled nut “A” to ensure there is an adequate ground connection. The measured resistance of the ground connection (between the readhead body and the shield connection at the controller end of the cable assembly) must be less than 1 ohm. Cable connection thread should be secured with Loctite 222.

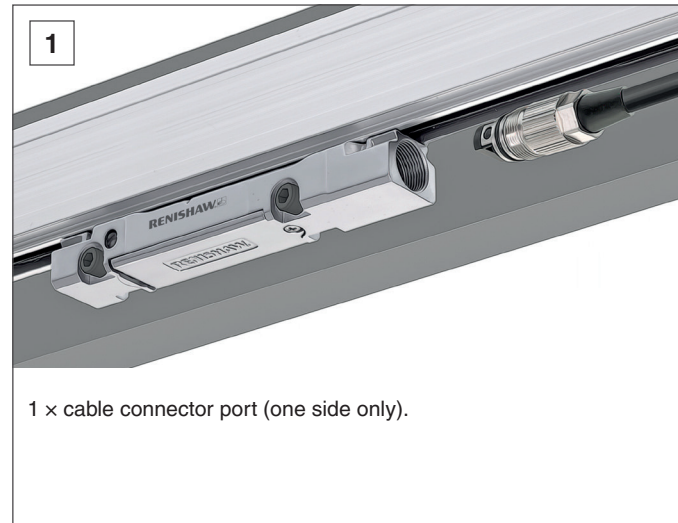

1 × cable connector port (one side only).

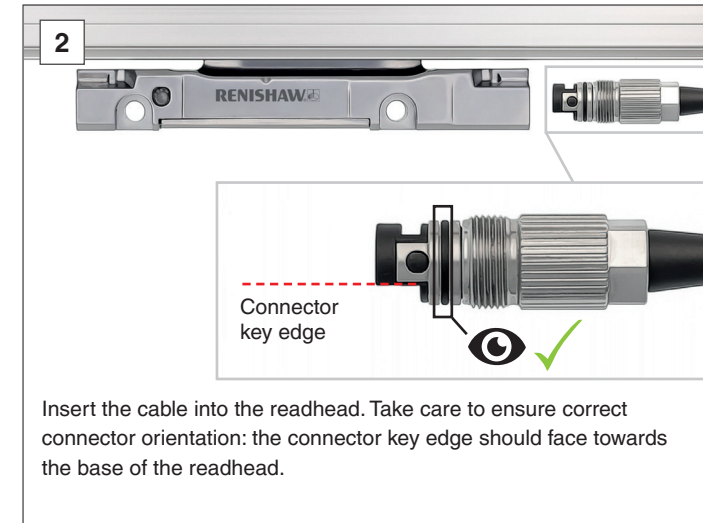

Insert the cable into the readhead. Take care to ensure correct connector orientation: the connector key edge should face towards the base of the readhead.

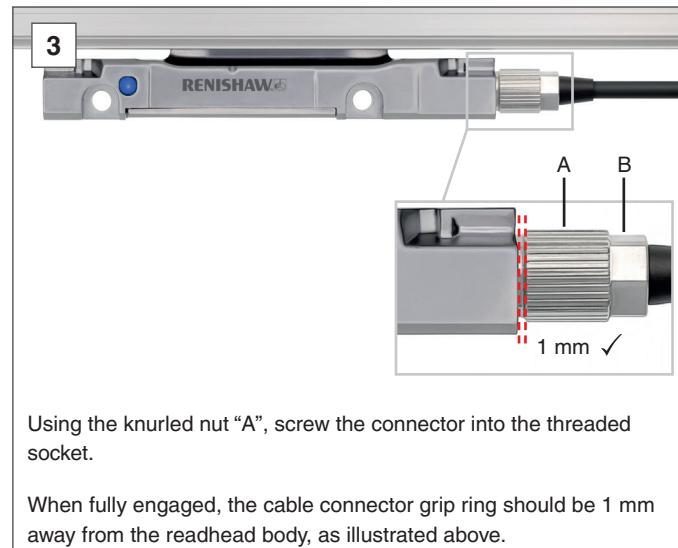

Using the knurled nut “A”, screw the connector into the threaded socket.

When fully engaged, the cable connector grip ring should be 1 mm away from the readhead body, as illustrated above.

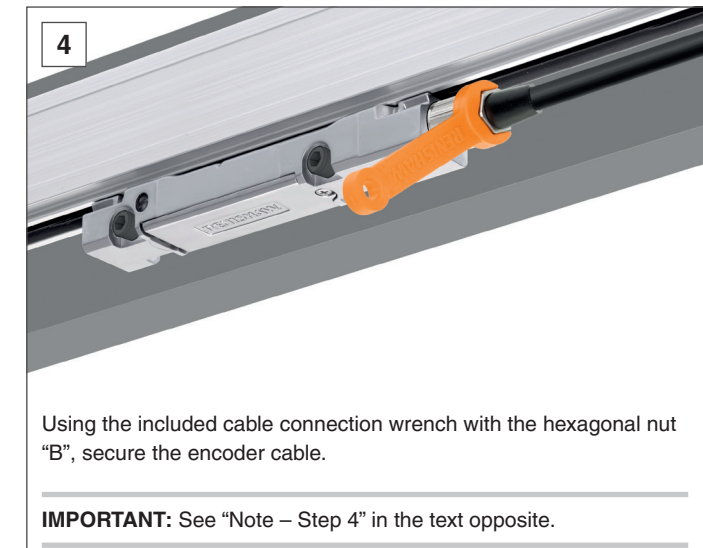

Using the included cable connection wrench with the hexagonal nut “B”, secure the encoder cable.





IMPORTANT: See “Note – Step 4” in the text opposite.

15.7 Validating an installation

To validate the encoder installation the set-up LED provides instant verification of the encoder's signal strength and therefore its accurate alignment and installation.

The encoder requires power to enable the set-up LED; this can be via an appropriate cable plugged into the machine's controller. See [section 16](#) on page 40 for encoder power supply requirements.

NOTE: If the set-up LED is obscured then the signal strength can be obtained using the Advanced Diagnostic Tool for absolute encoders (ADTa-100).

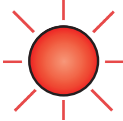
LED status	Description	Required action
 BLUE	Signal level is optimal	No adjustment required
 GREEN	Signal level is good	No adjustment required
 ORANGE	Signal level is acceptable	Ensure the extrusion is parallel to the machine axis of motion (see section 12 on page 20) and adjust the readhead to maximise the signal strength along the full axis of travel to achieve a Green or Blue LED
 RED	Signal level is NOT acceptable	
 FLASHING RED	Unable to determine the position	<p>The readhead not picking up the scale due to contamination or poor installation</p> <hr/> <p>NOTE: Flashing LED indicates scale reading error. Flashing state is latched for some serial interfaces.</p> <hr/> <p>Remove power to reset.</p> <hr/>

15.8 Air supply

FORTiS system encoders can be operated with an additional compressed air supply to increase the level of ingress protection from IP53 to IP64. If using air purge the air supply must meet pressure and cleanliness criteria as shown in the table below at the supply input of the encoder.

Air supply cleanliness requirements		
Air supply pressure	1 bar (pressure at encoder air inlet; air inlet connector has an integrated throttle that ensures the correct volume of airflow of 2 l/min through the encoder)	
Air quality	Particle size 0.1 µm to 0.5 µm 0.5 µm to 1.0 µm 1.0 µm to 5.0 µm	No. of particles per m ³ ≤ 20 000 ≤ 400 ≤ 10
Max pressure dew point	ISO 8573-1 Class 4 (pressure dew point at 3 °C)	
Total oil content	ISO 8573-1 Class 1 (max. oil concentration: 0.01 mg/m ³)	
Overpressure	Operating pressure range: Rating 0.7 MPa Maximum 1.0 MPa Minimum 0.3 MPa	

It may be convenient to connect the air purge supply to the system part that will be fixed, i.e., depending on the machine configuration and axis movement, either the extrusion or the readhead may move with the machine slideway.

Air inlets are included on both sides of the readhead and on both the extrusion end caps. Use a suitable air supply hose with a 4 mm bore.

For compatible air supply components refer to the data sheet *Air filtration systems for use with FORTiS encoders* (Renishaw part number L-9517-9982).

WARNING: Remove the blanking plug only from the position at which the purge air supply is to be connected, or the sealing integrity may be compromised.

NOTE: If an air bung or air connector screw requires replacement or repositioning it should be secured with Loctite 222.

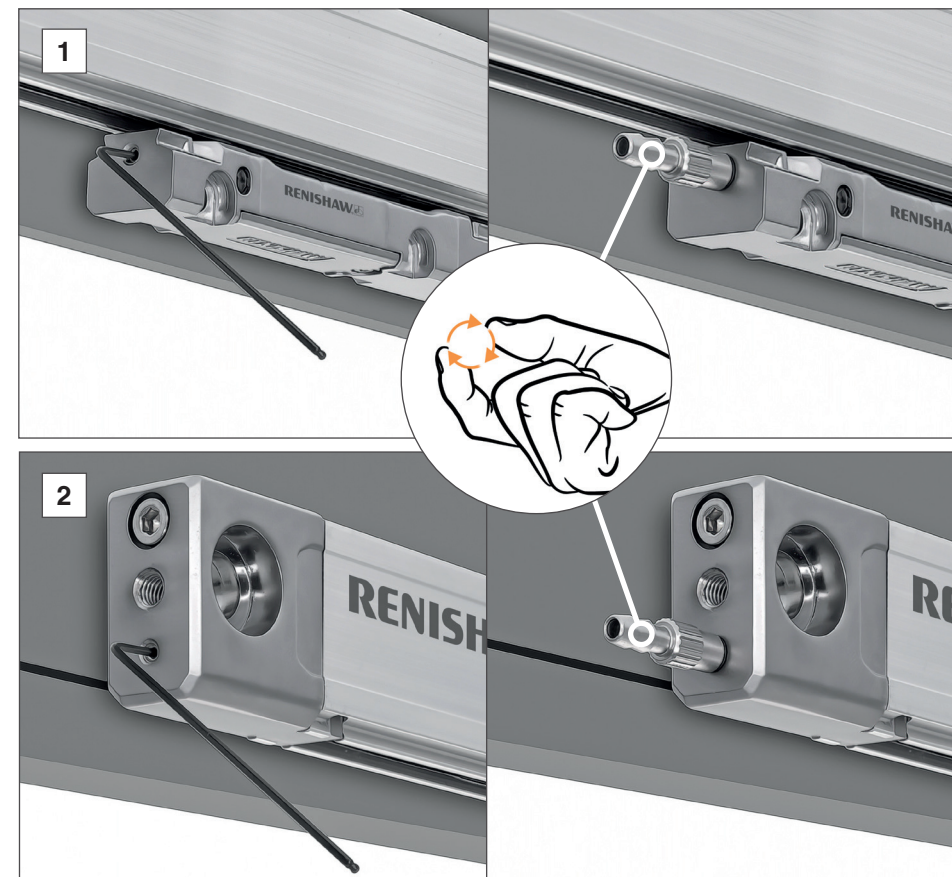

Removal of the air supply bung and fitment of the air connection fitting into either the readhead (1) or extrusion end cap (2). Finger tighten (0.3 Nm maximum).

16 Cables and serial interfaces

Further information relating to cables for the FORTiS encoder range can be found in the data sheet *Cables for FORTiS absolute encoders* (Renishaw part no. L-9517-0069). This can be downloaded from our website www.renishaw.com/fortisdownloads and is also available from your local Renishaw representative.

16.1 General specifications

Readhead cable	Type A	Ø4.7 mm, 28 AWG, 7 core, single screen, black jacket Flex life > 20 × 10 ⁶ cycles at 20 mm bend radius Minimum static bend radius (internal radius): 15 mm
	Type B	OD: 6.3 mm, 23 AWG, 6 core (3 × twisted pairs), single screen, green jacket Flex life > 20 × 10 ⁶ cycles at 75 mm bend radius Minimum static bend radius (internal radius): 31.5 mm
	Type D	Armoured: OD 10 mm, 28 AWG, 7 core Flex life > 20 × 10 ⁶ cycles at 100 mm bend radius Minimum static bend radius (internal radius): 35 mm
Extension cable (if applicable)	Type B	OD: 6.3 mm, 23 AWG, 6 core (3 × twisted pairs), single screen, green jacket Flex life > 20 × 10 ⁶ cycles at 75 mm bend radius Minimum static bend radius (internal radius): 31.5 mm
	Type C	OD: 7.8 mm, 2 × 20 AWG (power), 4 × 23 AWG (signal), 2 × 28 AWG (sense), single screen, green jacket Flex life > 20 × 10 ⁶ cycles at 75 mm bend radius Minimum static bend radius (internal radius): 58 mm

CAUTION: The FORTiS encoder system has been designed to the relevant EMC standards, but must be correctly integrated to achieve EMC compliance. In particular, attention to shielding arrangements is essential.

16.2 Permissible cable lengths

The tables below show permissible cable and extension cable combinations for the FORTiS range of enclosed linear encoders. For longer extension cable lengths, a shorter readhead cable is required.

This information is valid for all serial interfaces and connector types. At the worse case the minimum acceptable supply voltage is 4.5 Vdc.

NOTE: If the original termination supplied with the FORTiS-N FS encoder system is altered or a non-Renishaw cable that is not approved is used, then it is the responsibility of the system manufacturer to make sure the system is compliant with IEC 61800-5-2:2016 *Electromagnetic immunity requirement for safety related systems – Annex E, second environment*.

NOTE: For Siemens systems, the distance between the readhead and the DRIVE-CLiQ interface must adhere to the restrictions shown in the tables in this section, but the combination of readhead cable and extension cable MUST NOT EXCEED 10 m.

Readhead cable length (m)		Extension cable length (m)						
		1	3	6	9	12	15	20
Type A	0.5	✓	✓	✓	✓	✓	✓	✓
	1	✓	✓	✓	✓	✓	✓	✓
	3	✓	✓	✓	✓	✓	✓	✗
	6	✓	✓	✓	✓	✗	✗	✗
	9	✗	✗	✗	✗	✗	✗	✗
Type B	0.5	✓	✓	✓	✓	✓	✓	✓
	1	✓	✓	✓	✓	✓	✓	✓
	3	✓	✓	✓	✓	✓	✓	✓
	6	✓	✓	✓	✓	✓	✓	✓
	9	✓	✓	✓	✓	✓	✓	✗
Type D (armoured)	1	✓	✓	✓	✓	✓	✓	✓
	3	✓	✓	✓	✓	✓	✓	✗
	6	✓	✓	✓	✓	✗	✗	✗
	9	✗	✗	✗	✗	✗	✗	✗

Type B extension cables

Readhead cable length (m)	Max. extension cable length (m)	
Type A	0.5	55
	1	51
	3	38
	6	20
	9	1
Type B	0.5	56
	1	55
	3	51
	6	45
	9	39

Type C extension cables

16.3 BiSS Safety serial interface

Power supply	5 V ±10%	1.25 W maximum (250 mA @ 5 V)
NOTES:		
1. Current consumption figures refer to terminated FORTiS-N FS systems. Renishaw encoder systems must be powered from a 5 Vdc supply complying with the requirements for PELV of standard IEC 60950-1.		
2. Over voltage protection ±10 V.		
Ripple	200 mVpp maximum @ frequency up to 500 kHz	

16.3.1 Output signals

Function	Signal	Flying lead wire colour (F)	Pin-out		
			9-way D-type (A)	8-way M12 (S)	15-way D-type (D)
Power	5 V	Brown	4, 5	2	4, 12
	0 V	White	8, 9	5, 8	2, 10
Serial interface	MA+	Violet	2	3	8
	MA-	Yellow	3	4	15
	SLO+	Grey	6	7	5
	SLO-	Pink	7	6	13
Shield	Shield	Shield	Case	Case	Case

16.3.2 FORTiS-N FS grounding and shielding – BiSS Safety

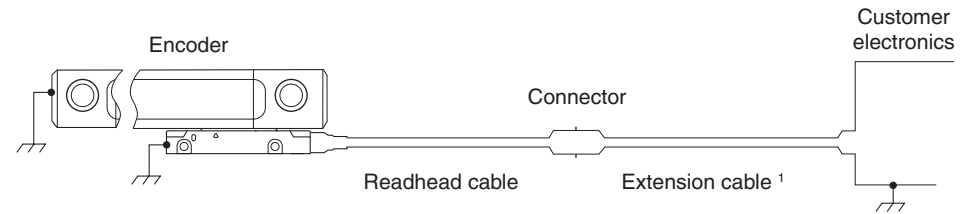

¹ For maximum extension cable length please consult your local Renishaw representative.

IMPORTANT:

1. The shield should be connected to the machine Earth (Field Ground).
2. If the flying lead variant is used or the connector is modified or replaced, the customer must ensure that both 0 V cores (white and green) are connected to 0 V. In such situations, care should also be taken to ensure that 0 V and Earth remain properly insulated from each other throughout the cable run.
3. If the original termination supplied with the FORTiS-N FS encoder system is altered or a non-Renishaw cable that is not approved is used, then it is the responsibility of the system manufacturer to make sure the system is compliant with IEC 61800-5-2:2016 *Electromagnetic immunity requirement for safety related systems – Annex E, second environment*.

16.3.3 Controller connector

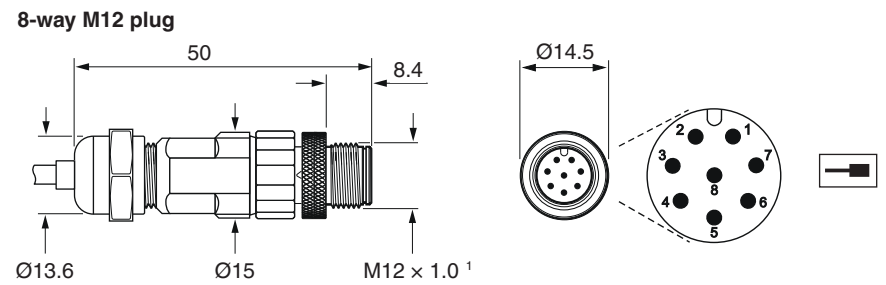
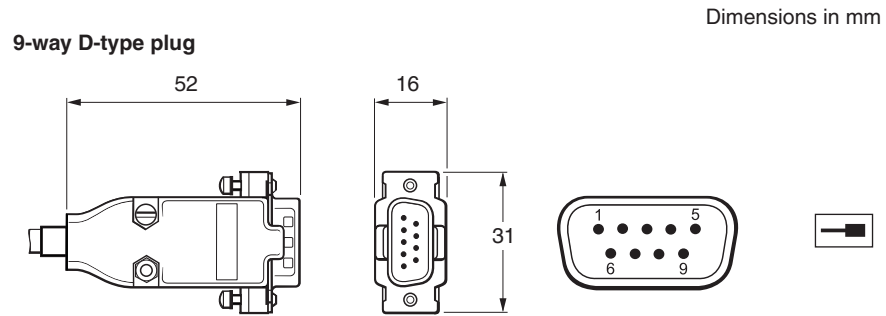

¹ The recommended tightening torque is 4 Nm.

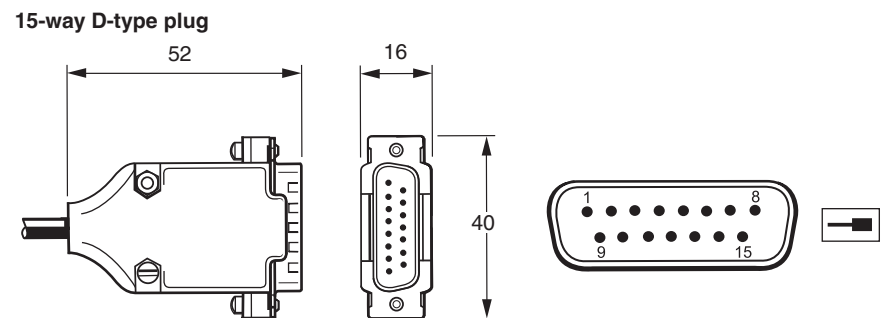

16.3.4 In-line connector

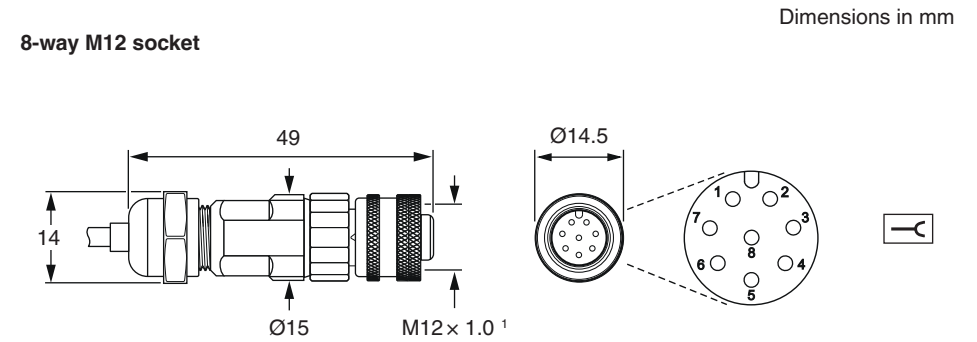

¹ The recommended tightening torque is 4 Nm.

16.4 Siemens DRIVE-CLiQ serial interface

Included with Siemens-only versions of FORTiS.

DRIVE-CLiQ interface connector		
Power supply	24 V	1.8 W maximum (75 mA @ 24 V), 24 V as per DRIVE-CLiQ specification. 24 V power is provided by the DRIVE-CLiQ network Overvoltage protection for DRIVE-CLiQ: -36V to +36V
Maximum total cable length		Readhead to DRIVE-CLiQ interface 9 m (Refer to Siemens DRIVE-CLiQ specifications for maximum cable length from interface to controller) Extension cables from the FORTiS-N FS DRIVE-CLiQ interface to the controller should be sourced directly from Siemens
Connector tightening torque		M12 – 4 Nm
Vibration (interface)		< 100 m/s ² to IEC 60068-2-6
Environment protection (interface)		IP67

16.4.1 Output signals

Function	Signal	Wire colour	Pin-out
			8-way M12 (S)
Power	5 V	Brown	2
	0 V	White	5, 8
Serial interface	A+	Violet	3
	A-	Yellow	4
Reserved	Do not connect	Grey	7
		Pink	6
Shield	Shield	Shield	Case

16.4.2 FORTiS-N FS grounding and shielding – Siemens DRIVE-CLiQ versions

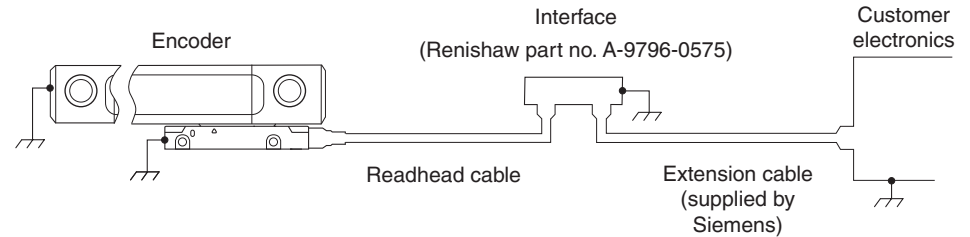

NOTE: On Siemens DRIVE-CLiQ systems the connector between the readhead cable and extension cable will mate via the A-9796-0575 interface.

IMPORTANT:

1. The shield should be connected to the machine Earth (Field Ground).
2. If the flying lead variant is used or the connector is modified or replaced, the customer must ensure that both 0 V cores (white and green) are connected to 0 V. In such situations, care should also be taken to ensure that 0 V and Earth remain properly insulated from each other throughout the cable run.
3. If the original termination supplied with the FORTiS-N FS encoder system is altered or a non-Renishaw cable that is not approved is used, then it is the responsibility of the system manufacturer to make sure the system is compliant with IEC 61800-5-2:2016 *Electromagnetic immunity requirement for safety related systems – Annex E, second environment*.

16.4.3 Controller connector

Dimensions in mm

8-way M12 plug

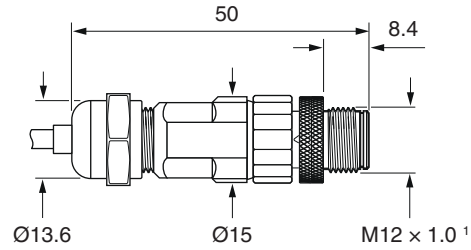

¹ The recommended tightening torque is 4 Nm.

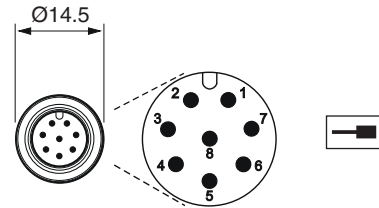

16.4.4 In-line connector

Dimensions in mm

8-way M12 socket

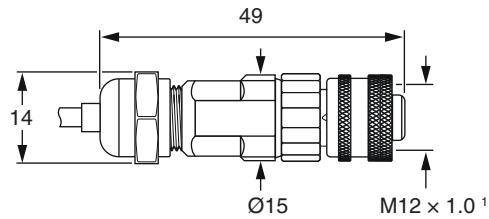

¹ The recommended tightening torque is 4 Nm.

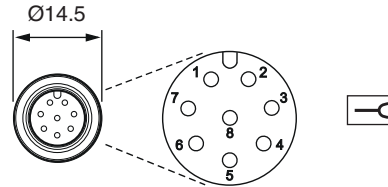

16.4.5 Siemens DRIVE-CLiQ serial interface

16.4.5.1 RDY LED functions

Colour	Status	Description
-	Off	Power supply is missing or outside permissible tolerance range
Green	Continuous light	The component is ready for operation and cyclic DRIVE-CLiQ communication is taking place
Orange	Continuous light	DRIVE-CLiQ communication is being established
Red	Continuous light	At least one fault is present in this component NOTE: The LED is activated regardless of whether the corresponding messages have been reconfigured.
Green/ orange or red/ orange	Flashing light	Component recognition via LED is activated (p0144) NOTE: Both options depend on the LED status when component recognition is activated via p0144=1.

16.4.5.2 Status LED function

STATUS displays the readhead set-up status as shown on the readhead set-up LED; see [section 15.7](#) on page 38 for more details.

16.4.6 Siemens DRIVE-CLiQ interface output

Function	Signal	Pin-out M12
Power	24 V	1
	0 V	5
DRIVE-CLiQ serial interface	RX+	3
	RX-	4
	TX+	7
	TX-	6
Shield	Shield	Case

16.4.7 Siemens DRIVE-CLiQ interface installation drawing

Single readhead (Renishaw part no. A-9796-0575)



Dimensions in mm

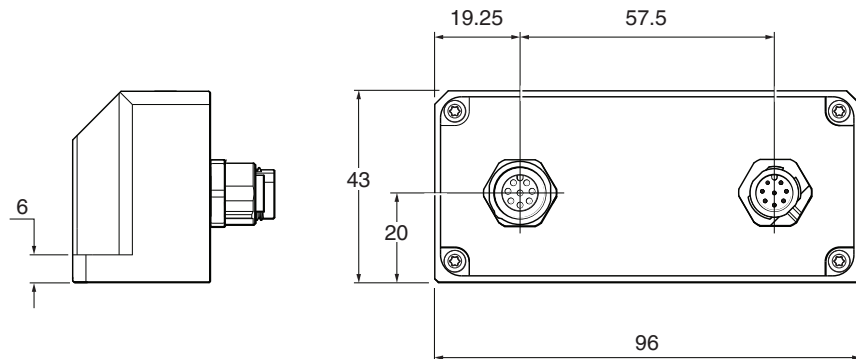
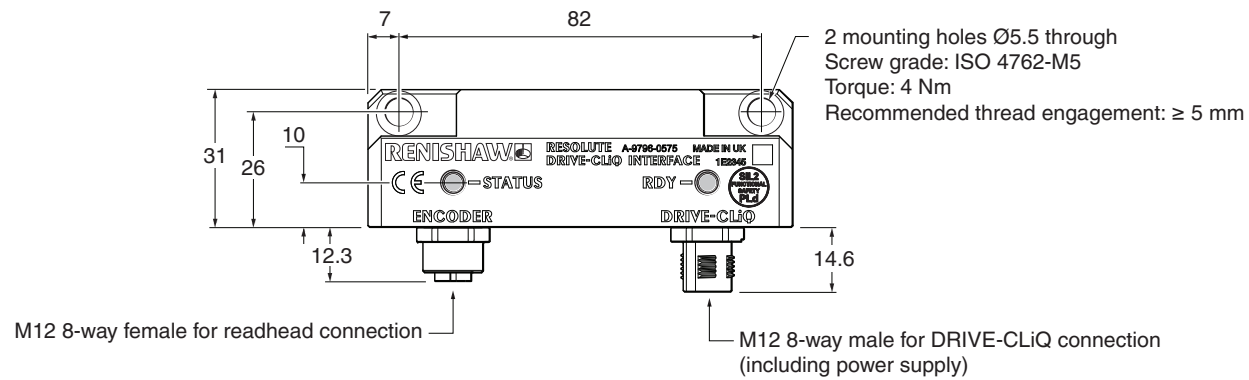

www.renishaw.com/contacts

 #renishaw

 +44 (0) 1453 524524

 uk@renishaw.com

© 2020–2023 Renishaw plc. All rights reserved. This document may not be copied or reproduced in whole or in part, or transferred to any other media or language by any means, without the prior written permission of Renishaw.
RENISHAW® and the probe symbol are registered trade marks of Renishaw plc. Renishaw product names, designations and the mark "apply innovation" are trade marks of Renishaw plc or its subsidiaries.
BiSS® is a registered trade mark of iC-Haus GmbH. Loctite® is a registered trade mark of the Henkel Corporation.
Other brand, product or company names are trade marks of their respective owners.
Renishaw plc. Registered in England and Wales. Company no: 1106260. Registered office: New Mills, Wotton-under-Edge, Glos, GL12 8JR, UK.

WHILE CONSIDERABLE EFFORT WAS MADE TO VERIFY THE ACCURACY OF THIS DOCUMENT AT PUBLICATION, ALL WARRANTIES, CONDITIONS, REPRESENTATIONS AND LIABILITY, HOWSOEVER ARISING, ARE EXCLUDED TO THE EXTENT PERMITTED BY LAW.

RENISHAW RESERVES THE RIGHT TO MAKE CHANGES TO THIS DOCUMENT AND TO THE EQUIPMENT, AND/OR SOFTWARE AND THE SPECIFICATION DESCRIBED HEREIN WITHOUT OBLIGATION TO PROVIDE NOTICE OF SUCH CHANGES.

Part no.: M-6725-9026-02-A
Issued: 05.2023